

iD LR-6



User Guide

R9010342

R59770134/01
27/05/2011



Barco nv Presentations

Noordlaan 5, 8520 Kuurne

Phone: +32 56.36.82.11

Fax: +32 56.35.86.51

Support: www.barco.com/esupport

Visit us at the web: www.barco.com

Changes

Barco provides this manual 'as is' without warranty of any kind, either expressed or implied, including but not limited to the implied warranties or merchantability and fitness for a particular purpose. Barco may make improvements and/or changes to the product(s) and/or the program(s) described in this publication at any time without notice.

This publication could contain technical inaccuracies or typographical errors. Changes are periodically made to the information in this publication; these changes are incorporated in new editions of this publication.

Copyright ©

All rights reserved. No part of this document may be copied, reproduced or translated. It shall not otherwise be recorded, transmitted or stored in a retrieval system without the prior written consent of Barco.

Disposal Information

This equipment has required the extraction and use of natural resources for its production. It may contain hazardous substances for health and environment. In order to avoid the dissemination of those substances in the environment and to diminish the pressure on natural resources, we encourage you to use the appropriate take-back systems. Those systems will reuse or recycle most of the materials of your end of life equipment in a sound way.



The crossed-out wheeled bin symbol invites you to use those systems. If you need more information on the collection, reuse and recycling systems, please contact your local or regional waste administrator. You can also contact us for more information on the environmental performances of our products.

EN55022/CISPR22 Class A ITE (Information Technology Equipment)

Class A ITE is a category of all other ITE which satisfies the class A ITE limits but not the class B ITE limits. Such equipment should not be restricted in its sale but the following warning shall be included in the instructions for use:

Warning : This is a class A product. In a domestic environment this product may cause radio interference in which case the user may be required to take adequate measures.

Federal Communications Commission (FCC Statement)

This equipment has been tested and found to comply with the limits for a class A digital device, pursuant to Part 15 of the FCC rules. These limits are designed to provide reasonable protection against harmful interference when the equipment is operated in a commercial environment. This equipment generates, uses, and can radiate radio frequency energy and, if not installed and used in accordance with the instruction manual, may cause harmful interference to radio communications. Operation of this equipment in a residential area may cause harmful interference, in which case the user will be responsible for correcting any interference at his own expense

Guarantee and Compensation

Barco provides a guarantee relating to perfect manufacturing as part of the legally stipulated terms of guarantee. On receipt, the purchaser must immediately inspect all delivered goods for damage incurred during transport, as well as for material and manufacturing faults Barco must be informed immediately in writing of any complaints.

The period of guarantee begins on the date of transfer of risks, in the case of special systems and software on the date of commissioning, at latest 30 days after the transfer of risks. In the event of justified notice of complaint, Barco can repair the fault or provide a replacement at its own discretion within an appropriate period. If this measure proves to be impossible or unsuccessful, the purchaser can demand a reduction in the purchase price or cancellation of the contract. All other claims, in particular those relating to compensation for direct or indirect damage, and also damage attributed to the operation of software as well as to other services provided by Barco, being a component of the system or independent service, will be deemed invalid provided the damage is not proven to be attributed to the absence of properties guaranteed in writing or due to the intent or gross negligence or part of Barco.

If the purchaser or a third party carries out modifications or repairs on goods delivered by Barco, or if the goods are handled incorrectly, in particular if the systems are commissioned operated incorrectly or if, after the transfer of risks, the goods are subject to influences not agreed upon in the contract, all guarantee claims of the purchaser will be rendered invalid. Not included in the guarantee coverage are system failures which are attributed to programs or special electronic circuitry provided by the purchaser, e.g. interfaces. Normal wear as well as normal maintenance are not subject to the guarantee provided by Barco either.

The environmental conditions as well as the servicing and maintenance regulations specified in the this manual must be complied with by the customer.

Trademarks

Brand and product names mentioned in this manual may be trademarks, registered trademarks or copyrights of their respective holders. All brand and product names mentioned in this manual serve as comments or examples and are not to be understood as advertising for the products or their manufacturers.

TABLE OF CONTENTS

1. Packaging	5
1.1 Unpacking	5
2. Installation guidelines	7
2.1 Safety warnings.....	7
2.2 Installation guidelines	7
3. Installation	9
3.1 Battery installation in the RCU	10
3.2 Lens installation	11
3.2.1 Lens installation	11
3.2.2 Removing the lens	11
3.2.3 Lens range	11
3.2.4 Lens Formulas	12
3.3 Projector configuration	12
3.4 Positioning the projector.....	13
3.5 Connections	16
3.5.1 Power connection.....	16
3.5.2 Input Source connections.....	16
3.5.2.1 Input section	17
3.5.2.2 Input facilities	17
3.5.2.3 5-Cable input	18
3.5.2.4 Composite Video Input	19
3.5.2.5 S-Video input	20
3.5.2.6 Digital Visual Interface (DVI) input.....	20
3.5.2.7 Computer input	21
3.5.2.8 Serial Digital Interface (Optional)	21
3.5.2.9 Audio input/Output (Optional).....	22
3.5.2.10 Communications Connections	23
3.5.2.10.1 RS232 IN connection	23
4. Setup	25
4.1 RCU & Local keypad	25
4.2 Terminology overview	26
4.3 Switching on	28
4.4 Setting the RCU address.....	29
4.5 Projector address.....	30
4.6 Orientation	31
4.7 Adjusting the lens.....	31
4.8 Preferences	33
4.8.1 Language.....	33
4.8.2 Quick access keys	34
4.8.3 Automatic startup	34
5. Getting started	37
5.1 Start up	37
5.2 Creating your personal PiP Layout	37
5.3 Adjusting the image	39
6. Advanced	41
6.1 Using the Dialog boxes.....	41
6.2 Source Selection	42
6.2.1 Source selection	42
6.2.2 Composite Video	43
6.2.3 S-Video	44
6.3 General menu	44
6.3.1 Pause.....	45
6.3.2 Freeze.....	45
6.3.3 Standby Timer.....	46
6.3.4 Audio (Optional).....	46
6.3.4.1 Audio Setup	46
6.3.4.2 Audio Settings	47
6.3.5 Identification.....	48
6.4 Image menu	49
6.4.1 Settings.....	49
6.4.1.1 Contrast.....	50
6.4.1.2 Brightness	51
6.4.1.3 Color	51
6.4.1.4 Tint (hue)	51
6.4.1.5 Sharpness	52
6.4.1.6 Gamma	52
6.4.1.7 Phase	52
6.4.1.8 Noise reduction	53

6.4.2	Aspect ratio	53
6.4.3	Show native resolution	55
6.4.4	Keystone	57
6.4.5	Color temperature	58
6.4.6	Film mode detection (video only)	58
6.4.7	White peaking	60
6.4.8	Dynacolor™	61
6.4.9	Blanking	70
6.4.10	Input balance	70
6.4.11	AGC on Video	73
6.4.12	Manual Gain Control	74
6.5	Tools	75
6.5.1	Introduction to PiP	75
6.5.2	PiP select	76
6.5.3	PiP add window	77
6.5.4	PiP remove window	78
6.5.5	PiP layout	78
6.5.5.1	PiP Save	78
6.5.5.2	PiP rename layout	79
6.5.5.3	PiP delete layout	80
6.5.6	PiP Adjust	80
6.5.7	Color keying	81
6.5.8	Diagnostics	82
6.6	Signal Menu	82
6.6.1	Switching mode	82
6.6.2	Background	83
6.7	Lamp management	84
6.7.1	Runtimes	84
6.7.2	Mode	84
6.7.3	History	86
6.7.4	Runtime warning	86
6.8	Image files menu	87
6.8.1	Load file	87
6.8.2	Auto Image	88
6.8.3	Edit file	89
6.8.4	Rename file	93
6.8.5	Copy	94
6.8.6	Delete	95
6.8.7	Forced file load	95
6.9	Display Setup	96
6.9.1	Full screen representation	96
6.9.2	Startup screen	97
6.9.3	Textbox	97
6.9.4	Take screenshot	98
6.9.5	Menu bar position	98
6.9.6	Status bar position	98
6.9.7	Sliderbox position	99
6.9.8	AutoImage Setup	99
6.9.9	Blanking	100
6.9.10	Soft Edge	101
6.9.10.1	Introduction	101
6.9.10.2	Soft Edge overlap zone (horizontal Soft Edge)	103
6.9.10.3	Soft Edge border adjustment	103
6.9.10.4	Black level of the images	105
6.10	Installation	106
6.10.1	Lens adjustments	107
6.10.2	Security	107
6.10.3	Change password	110
7.	Image files	111
7.1	Table overview	111
8.	Troubleshoot	115
8.1	Using the OSD	115
9.	Maintenance	117
9.1	Cleaning the lens	117
9.2	Cleaning the dustfilters	117
9.2.1	Dustfilters	117
9.2.2	Cleaning	118
9.3	The UHP Lamp	120
9.3.1	Reset lamp runtime	120
9.3.1.1	Reset runtime	120
9.3.2	Removing the lamp unit(s)	121
9.3.3	Mounting the lamp unit(s)	123

Glossary	125
Index.....	127
List of images.....	131

1. PACKAGING

1.1 Unpacking



CEE7/7

European power plug to connect the power cord to the wall outlet.



NEMA5

American power plug to connect the power cord to the wall outlet.

Content

- 1 projector (weight \pm 14 kg or 31 lbs)
- 1 remote control unit RCU + 2 batteries.
- 2 power cables with outlet plug type CEE7 and ANSI 73.11.
- 1 owners manual
- 1 safety manual
- 1 CDROM (containing manuals)

Form

The projector is packed in a carton box. To provide protection during transportation, the projector is surrounded with foam. The package is secured with banding and fastening clips.

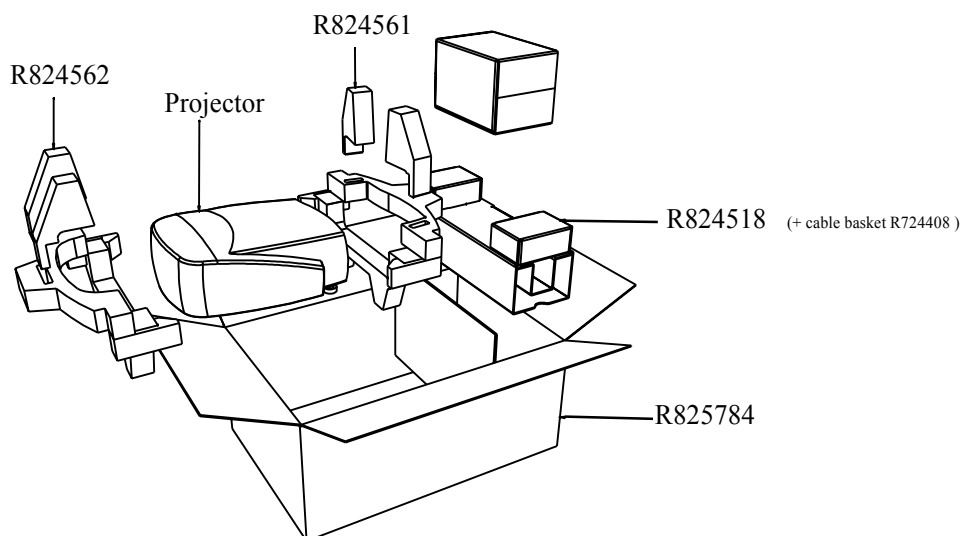

Image 1-1

Lens packaging

The Lens is supplied as an individual item.

The lens is packed in a carton box.



Save the original shipping cardboard and packing material, they will be necessary if you ever have to transport the lens.



CAUTION: Never transport the projector with the lens mounted on it !
Always remove the lens before transporting the projector.

How to unpack the projector

1. Release the cord straps.

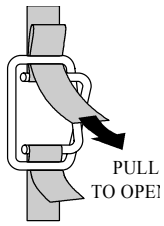

Image 1-2

2. Remove the assembly from the pallet
3. Remove the cardboard cover
4. Remove the large cardboard
5. Remove the 8 foam parts
6. Loosen and remove the 3 screws spacers fixing the projector to the wooden board
7. Remove the projector from the board



Save the original shipping carton and packing material, they will be necessary if you ever have to ship your projector. For maximum protection, repack your projector as it was originally packed at the factory.

2. INSTALLATION GUIDELINES

2.1 Safety warnings



WARNING: Before installing the projector, first read the safety instructions in the safety manual (R5975258) delivered with the projector.

Insure that the room can be easily evacuated in case of a lamp explosion.

Mercury vapor warnings

Keep the following warnings in mind when using the projector. The lamp used in the projector contains mercury. In case of a lamp rupture or lamp explosion there will be a mercury vapor emission. In order to minimize the potential risk of inhaling mercury vapors:

- Insure the projector is installed in ventilated rooms only.
- Replace the lamp module before the end of its operational life.
- Promptly ventilate the room after a lamp rupture or lamp explosion has occurred and evacuate the room (particularly in case of a pregnant woman).
- Seek medical attention if unusual health conditions occur after a lamp rupture or lamp explosion, such as headache, fatigue, shortness of breath, chest-tightening coughing or nausea.

2.2 Installation guidelines

Ambient temperature check

Careful consideration of things such as image size, ambient light level, projector placement and type of screen to use are critical to the optimum use of the projection system.

Max. ambient temperature : 40 °C or 104 °F

Min. ambient temperature : 0 °C or 32 °F

The projector will not operate if ambient air temperature falls outside this range (0°C- 40°C or 32°F-104°F).

Environment

Do not install the projection system in a site near heat sources such as radiators or air ducts, or in a place subject to direct sunlight, excessive dust or humidity. Be aware that room heat rises to the ceiling; check that temperature near the installation site is not excessive



CAUTION: Harmful Environmental Contamination Precaution

Environment condition check

A projector must always be mounted in a manner which ensures the free flow of clean air into the projectors ventilation inlets as well as free flow at the ventilation outlets. The installation must also allow easy access to the consumable parts (dustfilters, lamps, ...) For installations in environments where the projector is subject to airborne contaminants such as that produced by smoke machines or similar (these deposit a thin layer of greasy residue upon the projectors internal optics and imaging electronic surfaces, degrading performance), then it is highly advisable and desirable to have this contamination removed prior to it reaching the projectors clean air supply. Devices or structures to extract or shield contaminated air well away from the projector are a prerequisite, if this is not a feasible solution then measures to relocate the projector to a clean air environment should be considered. Make sure that the projector never runs with dirty dustfilters as this will dramatically reduce the lifetime of the consumables. It is advised to clean the dustfilters on a regular basis and to replace them at any lamp change. Barco reserves itself the right to refuse warranty replacement of consumables if they have been used in a projector with dirty airfilters. Only use the manufactures recommended cleaning kit which has been specifically designed for cleaning optical parts, never use industrial strength cleaners on a projectors optics as these will degrade optical coatings and damage sensitive optoelectronics .

Failure to take suitable precautions to protect the projector from the effects of persistent and prolonged air contaminants will culminate in extensive and irreversible ingrained optical damage. At this stage cleaning of the internal optical units will be non-effective and impracticable. Damage of this nature is under no circumstances covered under the manufactures warranty and may deem the warranty null and void. In such a case the client shall be held solely responsible for all costs incurred during any repair. It is the clients responsibility to ensure at all times that the projector is protected from the harmful effects of hostile airborne particles in the environment of the projector. The manufacture reserves the right to refuse warranty repair if a projector has been subject to wantful neglect, abandon or improper use.

What about ambient light ?

The ambient light level of any room is made up of direct or indirect sunlight and the light fixtures in the room. The amount of ambient light will determine how bright the image will appear. So, avoid direct light on the screen. Windows that face the screen should be covered by opaque drapery while the set is being viewed. It is desirable to install the projection system in a room whose walls and floor are of non-reflecting material. The use of recessed ceiling lights and a method of dimming those lights to an acceptable level is also important. Too much ambient light will 'wash out' of the projected image. This appears as less contrast between the darkest and lightest parts of the image. With bigger screens, the 'wash out' becomes more important. As a general rule, darken the room to the point where there is just sufficient light to read or write comfortably. Spot lighting is desirable for illuminating small areas so that interference with the screen is minimal.

Which screen type ?

There are two major categories of screens used for projection equipment. Those used for front projected images and those for rear projection applications. Screens are rated by how much light they reflect (or transmit in the case of rear projection systems) given a determined amount of light projected toward them. The 'GAIN' of a screen is the term used. Front and rear screens are both rated in terms of gain. The gain of screens range from a white matte screen with a gain of 1 (x1) to a brushed aluminized screen with a gain of 10 (x10) or more. The choice between higher and lower gain screens is largely a matter of personal preference and another consideration called the Viewing angle. In considering the type of screen to choose, determine where the viewers will be located and go for the highest gain screen possible. A high gain screen will provide a brighter picture but reduce the viewing angle. For more information about screens, contact your local screen supplier.

Image size

The projector is designed for projecting an image size with a screenwidth from 1.00m (3.3ft) to 6.00m (19.7ft) with an aspect ratio of 4 to 3.

Image retention

Image retention can affect LCD projectors, in extreme cases, permanent "burn" can occur if still/repetitive images are left on the screen for long periods of time. Such damage to the panels is NOT covered by warranty.

Please ensure that the following precautions are taken to avoid this phenomenon :

1. Use a screensaver (that moves)
2. Periodically change/alter any background images on the desktop
3. Turn off the projector when not in use.

3. INSTALLATION

Overview

- Battery installation in the RCU
- Lens installation
- Projector configuration
- Positioning the projector
- Connections

Dimensions overview

Dimensions are given in mm (1 inch = 25.4 mm)

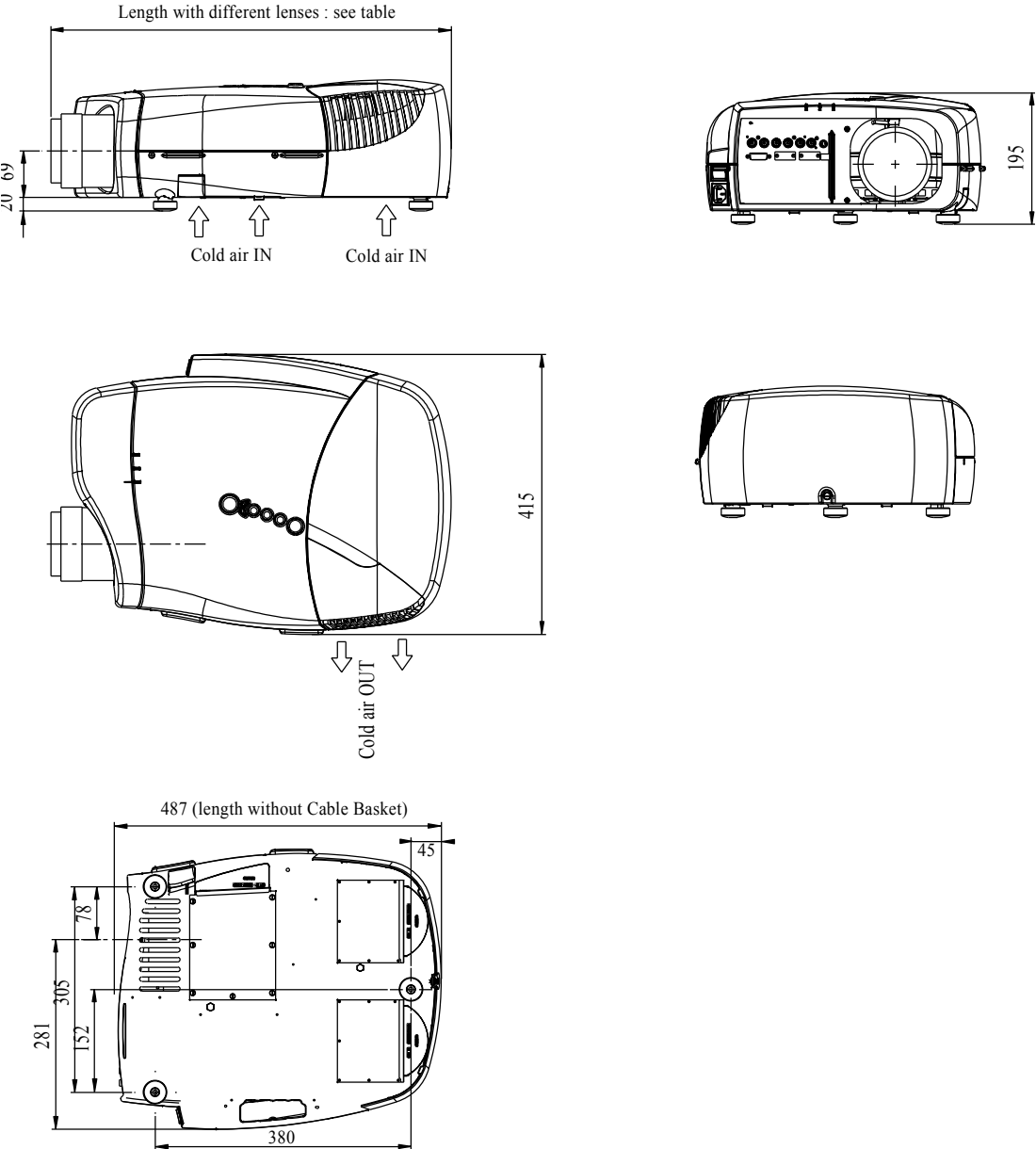

3. Installation

Lens	Length of projector
CLD (1.2-1.6:1)	530 mm
CLD (1.6-2.4:1)	525 mm
CLD (2.4-4.3:1)	550 mm
QCLD (1.1-1.3:1)	580 mm
QCLD (0.85:1)	610 mm

3.1 Battery installation in the RCU

How to install the battery

Two batteries are packed together with the RCU. Before using your RCU, install first these batteries.

1. Remove the battery cover on the backside by pushing the handle a little towards the bottom of the RCU.
2. Lift up the top side of the cover at the same time.
3. Insert the batteries as indicated in the RCU.
4. Put the battery cover on its place.

How to replace the batteries in the RCU

To replace the batteries :

1. Remove the battery cover on the backside by pushing the handle a little towards the bottom of the RCU.
2. Lift up the top side of the cover at the same time.
3. Push on the + side of the battery towards the - side
4. Lift up the battery at the same time.
5. Repeat for the second battery.
6. Insert the batteries as indicated in the RCU (battery type AA or LR6 or equivalent).
7. Put the battery cover on its place.

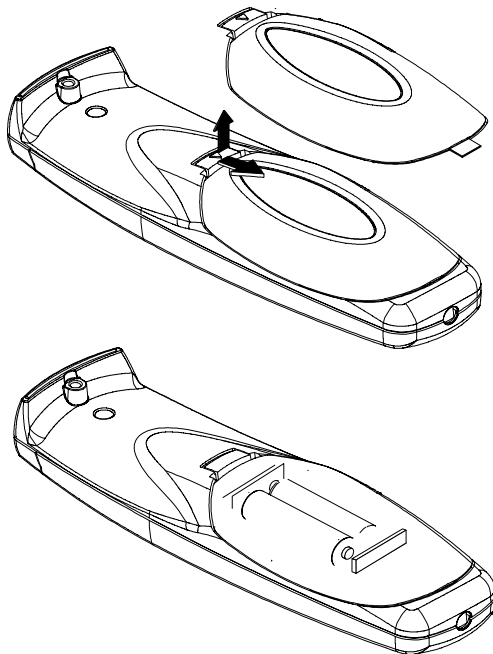

Image 3-2

3.2 Lens installation

3.2.1 Lens installation

How to install ?

1. Take the lens out of its packing material
2. Fix the lens by placing it in the housing



Image 3-3

Note: In case of a motorized lens the female jack must be in front of the male jack located in the upper-left part of the housing in the projector

3. Push carefully to lock the lens in the housing

3.2.2 Removing the lens

How to remove the lens ?

1. Unlock the lens by pulling the handle located on the right side of the projector



Image 3-4



Image 3-5
location of the lens handle

2. Remove the lens out of its housing



CAUTION: Never transport the projector with the lens mounted on it !
Always remove the lens before transporting the projector.

3.2.3 Lens range

Overview table

Lens	Partnumber
CLD (1.2-1.6:1)	R9849870
CLD (1.6-2.4:1)	R9849880

3. Installation

Lens	Partnumber
CLD (2.4-4.3:1)	R9849890
QCLD (1.1-1.3:1)	R9849850
QCLD (0.85:1)	R9849860



See the Maintenance appendix for more information about lens cleaning.

3.2.4 Lens Formulas

Formulas

Lenses	Metric Formulas (meter)	Inch formulas (inch)
QCLD (0.85:1)	$PD = 0.86 \times SW + 0.06$	$PD = 0.86 \times SW + 2.36$
QCLD (1.1-1.3:1)	$PD_{min} = 1.1 \times SW + 0.05$ $PD_{max} = 1.3 \times SW + 0.06$	$PD_{min} = 1.1 \times SW + 1.97$ $PD_{max} = 1.3 \times SW + 2.36$
CLD (1.2-1.6:1)	$PD_{min} = 1.19 \times SW + 0.02$ $PD_{max} = 1.63 \times SW + 0.02$	$PD_{min} = 1.19 \times SW + 0.79$ $PD_{max} = 1.63 \times SW + 0.79$
CLD (1.6-2.4:1)	$PD_{min} = 1.58 \times SW + 0.00$ $PD_{max} = 2.39 \times SW - 0.02$	$PD_{min} = 1.58 \times SW + 0.00$ $PD_{max} = 2.39 \times SW - 0.79$
CLD (2.4-4.3:1)	$PD_{min} = 2.38 \times SW - 0.03$ $PD_{max} = 4.32 \times SW - 0.01$	$PD_{min} = 2.38 \times SW - 1.18$ $PD_{max} = 4.32 \times SW - 0.39$

3.3 Projector configuration

The different configurations

Depending on the installation the projector can be mounted in different ways, the 4 different configurations are:

1. Rear/Ceiling
2. Rear/Table
3. Front/Ceiling
4. Front/Table

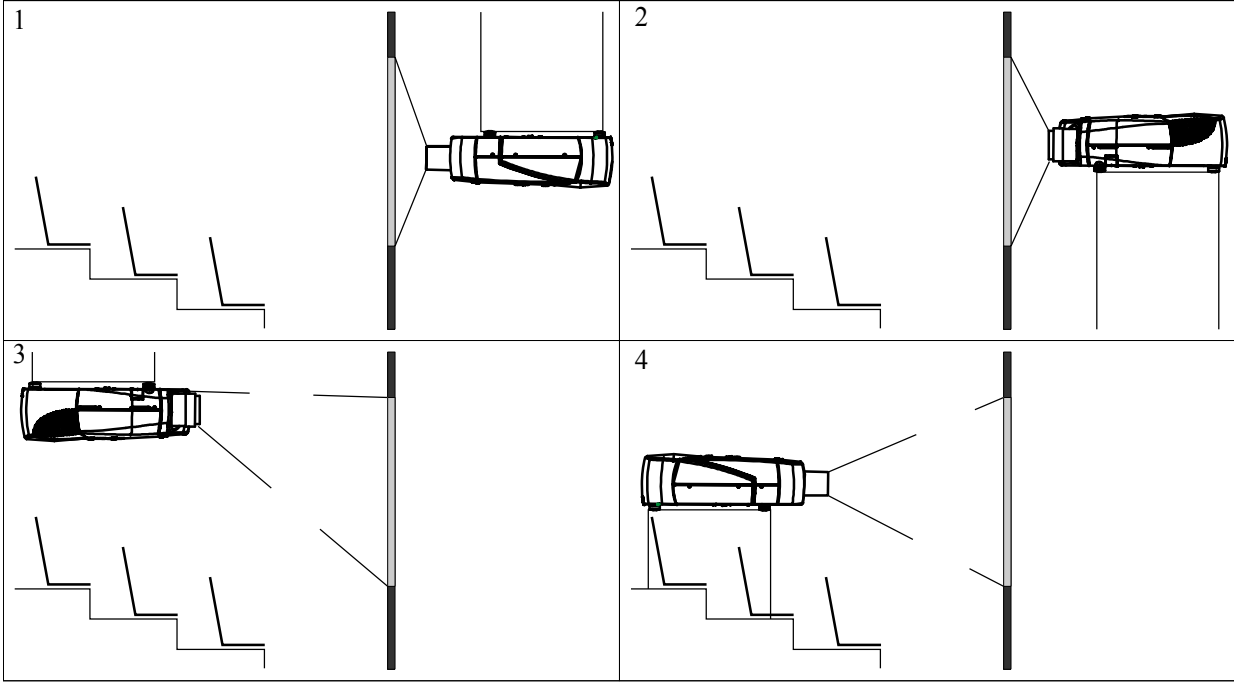

Image 3-6



The configuration should also be communicated to the projector. This is done in the *Installation* menu through the *Projector Configuration* parameter. (See Setup section)

3.4 Positioning the projector



On-Axis projection

Projection where the projector is positioned so as to have the centre of the lens coinciding with the centre of the screen.

Positioning the projector

The position of the projector with reference to the screen may also be different depending on the installation. Basically the projector can be positioned in an On-Axis or Off-Axis configuration. Several parameters can be calculated determining the position in any installation.

3. Installation

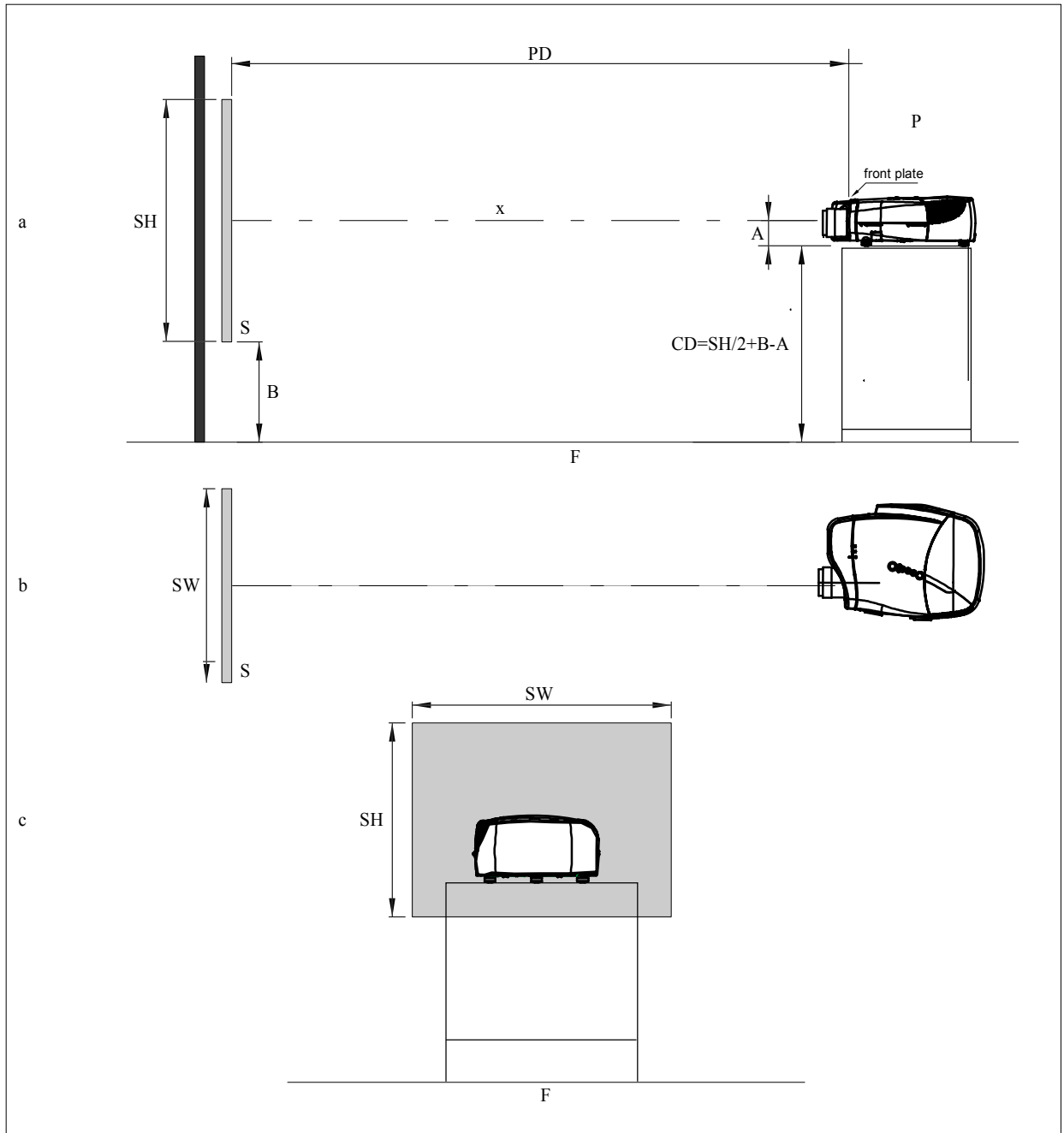

Image 3-7

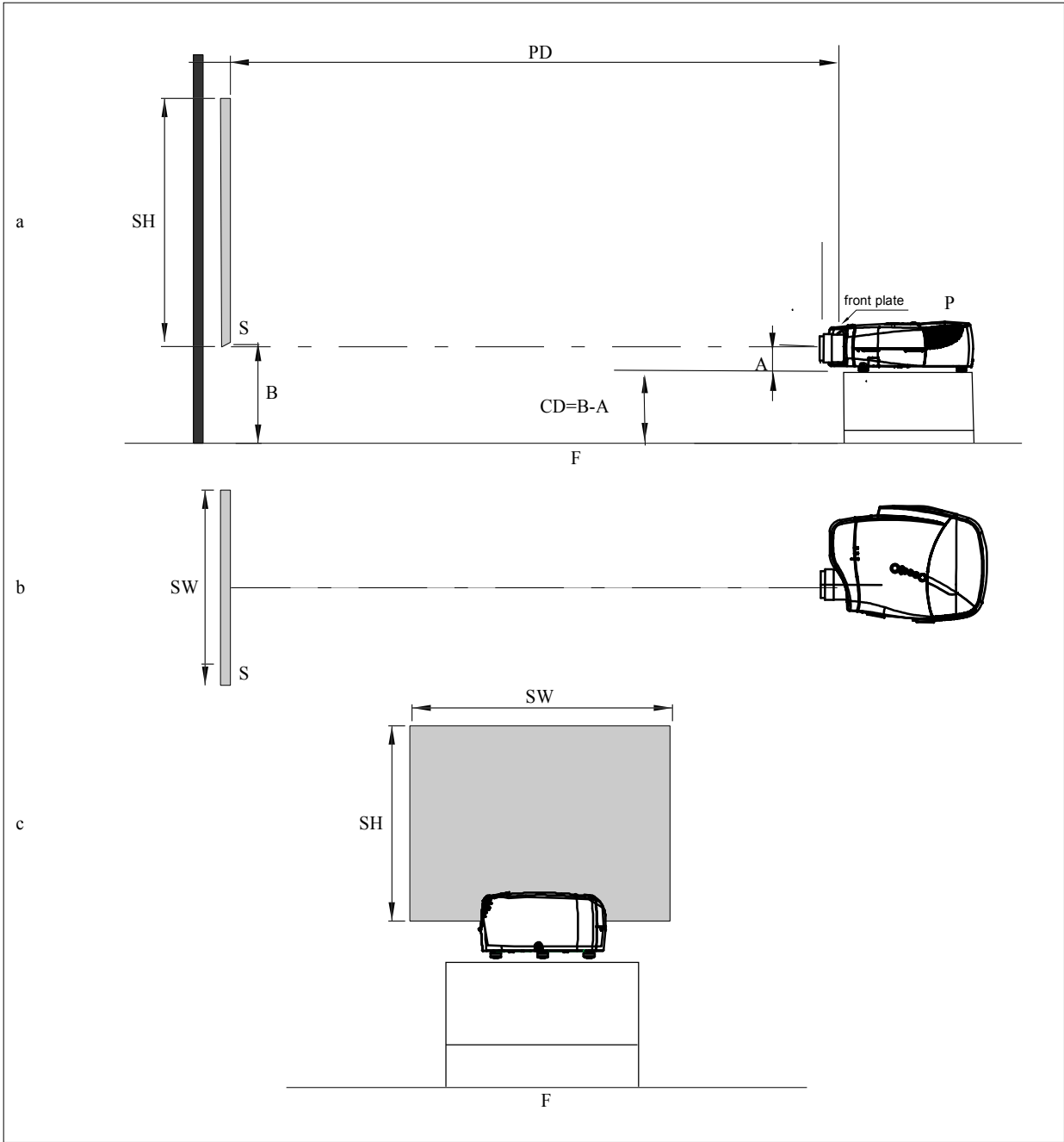

Image 3-8



A 100% Off-Axis position means that the position of the centre of the lens is shifted by half the screen height.



Never use a short throw lens in an Off-Axis installation. Shifting the lens will not guarantee optimal image quality.



CAUTION: Only for projectors containing a Server (Single Board Computer) : The hard disk in the server is formatted in horizontal position but can operate in all axes (6 directions). The projector should not be tilted more then +/- 5 degrees from these positions, otherwise error rates will increase.



CAUTION: Never place the projector on either side !

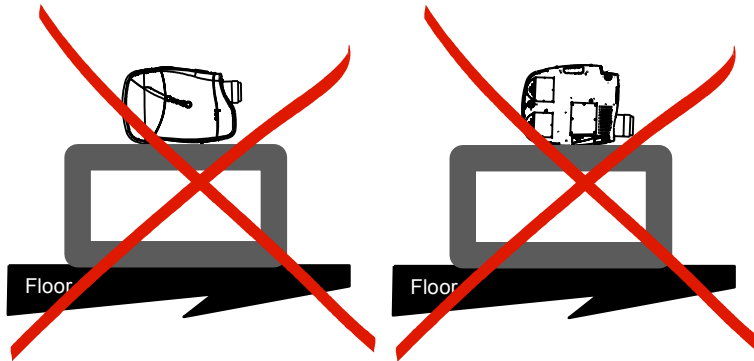

Image 3-9

3.5 Connections

3.5.1 Power connection

AC power (mains) cord connection

Use the supplied power cord to connect your projector to the wall outlet.

Plug the female power connector into the male connector at the front of the projector.



The power input is auto-ranging from 90 to 240 VAC.

Fuses

For continued protection against fire hazard :

- refer replacement to qualified service personnel
- ask to replace with the same type of fuse.

3.5.2 Input Source connections

Overview

- Input section
- Input facilities
- 5-Cable input
- Composite Video Input
- S-Video input
- Digital Visual Interface (DVI) input
- Computer input
- Serial Digital Interface (Optional)
- Audio input/Output (Optional)
- Communications Connections

3.5.2.1 Input section

Input Layers

The input section is divided in layers, each of them regrouping several inputs, this architecture allows the input section to be upgraded at any time with an optional analog or digital layer.

1. Layer 1: analog layer containing analog data and video inputs
2. Layer 2: a hybrid layer containing 2 digital and 1 analog input
3. Layer 3 : is an optional layer, it may be an Audio & Video analog layer or a SDI digital layer.



The optional layer is not available for the Pro version

3.5.2.2 Input facilities



The optional features are also explained in this manual, they are always mentioned with “(optional)”



The SDI and Audio option is not possible on the Pro version !

overview

- 5-cable input
- composite video
- component video (PR/Y/PB)
- S-Video
- Digital Visual Input (DVI)
- Computer
- Serial Digital Input (Optional)
- Audio input/output (Optional)



Layer 3 can be an optional audio&video layer or an optional SDI (SDI Input/Output)

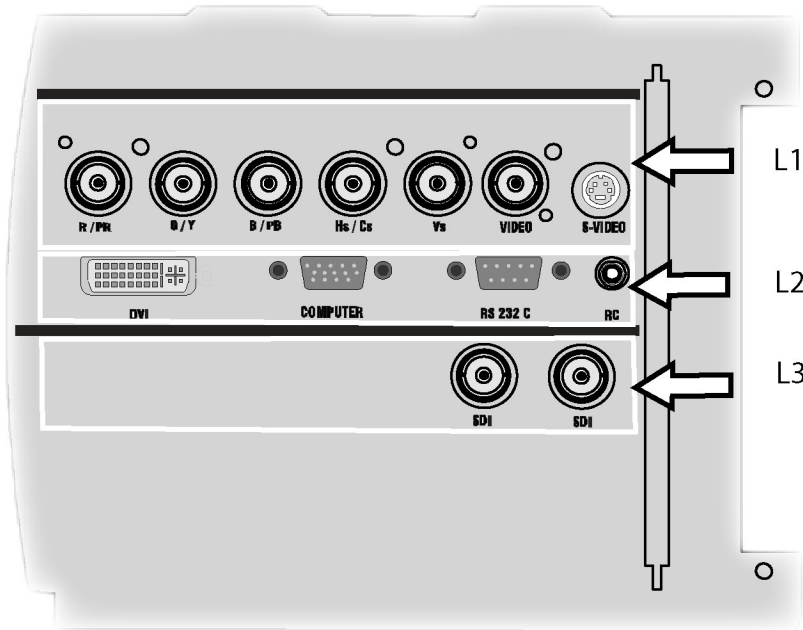

Image 3-10
source input section with optional SDI layer



A cable cover is supplied with the projector and can be fitted on the front of the projector

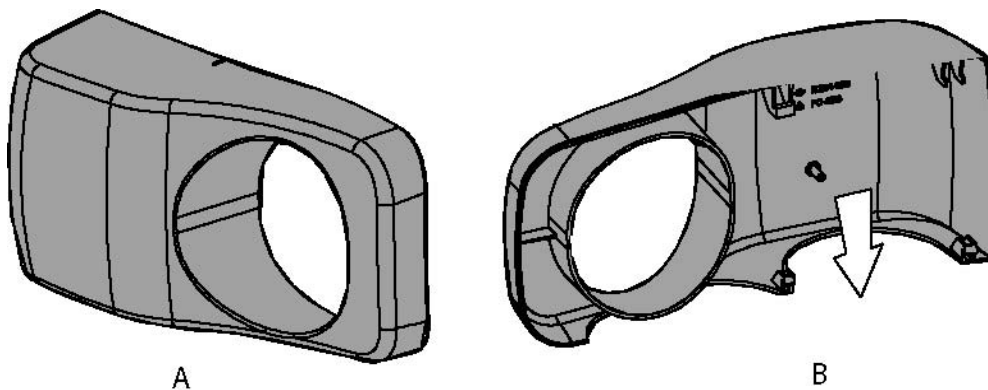

Image 3-11
Cable basket : the white arrow shows the cables leaving the projector

- A Front view
- B Back view

3.5.2.3 5-Cable input

Input specifications

The 5-cable input section is made of 5 BNC input terminals.

0.7 Vpp ± 3dB

75 Ω terminated

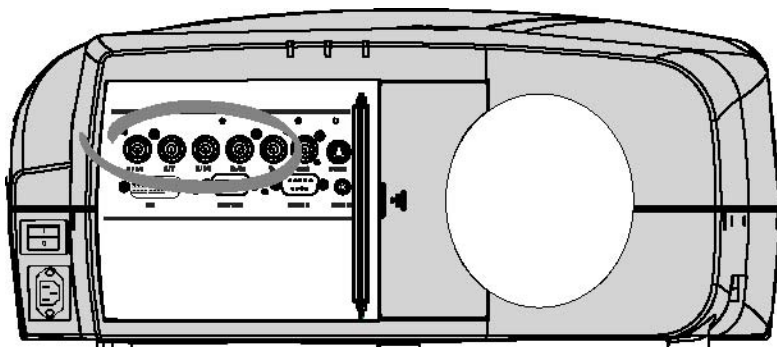

Image 3-12



Component Video

In Component Video the term component describes a number of elements that are needed to make up the video picture, these components are PR/Y/PB. A composite video signal on the other hand contains all the information needed for the color picture in a single channel of information

Which signals can be connected ?

Signals/Input BNC	R	G	B	H	V
RGBHV	R	G	B	H	V
RG _s B ¹	R	G _s	B	-	-
RGBS ¹	R	G	B	S	-
Component	PR	Y	PB	-	-

How to select a source on the 5 cable input ?

1. Press 1 on the RCU

Note: Another way for selecting this input is via **Source** on the local keypad or via the Menu

3.5.2.4 Composite Video Input

Input specifications

The Composite video input section is made of 1BNC input terminal.

1.0 Vpp ± 3dB

75 Ω terminated

No loop through

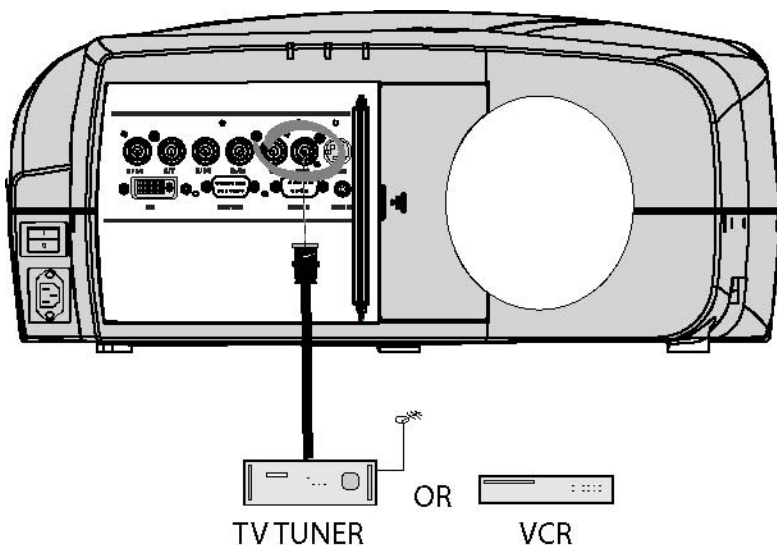

Image 3-13

How to select a Composite Video Input ?

1. Press **3** on the RCU

Note: Another way for selecting this input is via **Source** on the local keypad or via the **Menu**.

3.5.2.5 S-Video input

Input specification

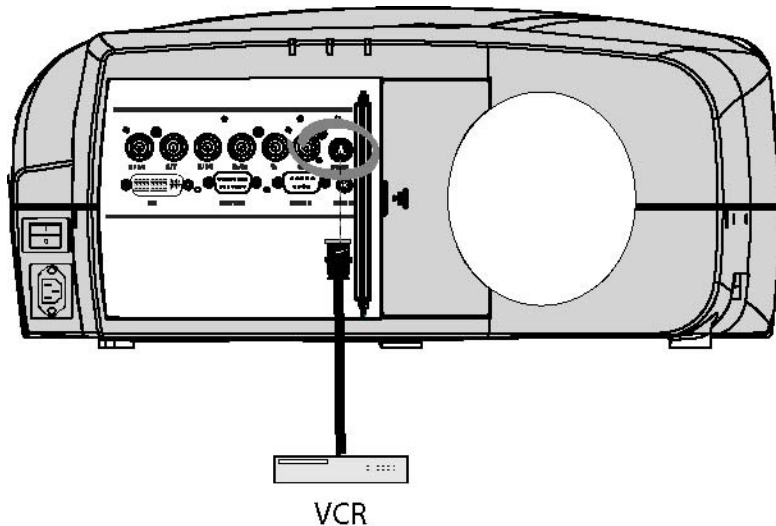

Image 3-14

Which signal can be connected ?

Standard S-Video (S-VHS) with separate Y(luma) and C (chroma) signals.

How to select the S-Video input ?

1. Press **4** on the RCU

Note: Another way for selecting this input is via **Source** on the local keypad or via the **Menu**.

3.5.2.6 Digital Visual Interface (DVI) input



DVI

Digital Visual Interface is a display interface developed in response to the proliferation of digital flat panel displays.

The digital video connectivity standard that was developed by DDWG (Digital Display Work Group). This connection standard offers two different connectors: one with 24 pins that handles digital video signals only, and one with 29 pins that handles both digital and analog video. This standard uses TMDS (Transition Minimized Differential Signal) from Silicon Image and DDC (Display Data Channel) from VESA (Video Electronics Standards Association).

DVI can be single or dual link.

Input specifications

Single link DVI

Differential input voltage: 200 mV - 800mV

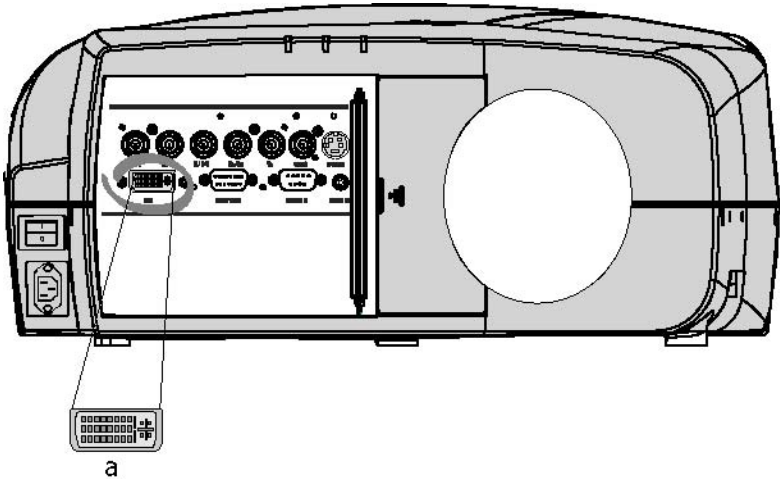

Image 3-15
a DVI-I type connector, analog link (4 pins at the right side of the connector) not supported

How to select the DVI Input ?

1. Press **5** on the RCU
Note: Another way for selecting this input is via the Menu.

3.5.2.7 Computer input

Input specification

TTL sync input : $U_{min} = 2.0 V$
RGB input = $0.7 V_{pp} \pm 3dB$

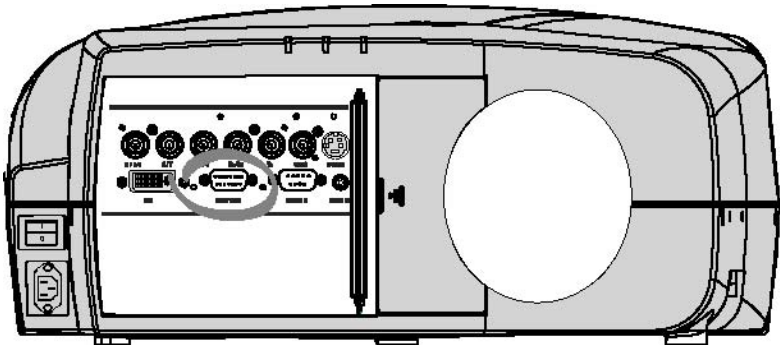

Image 3-16

What can be connected ?

- RGBHV
- RG_SB



Composite sync only possible on Green

How to select a computer input ?

1. Press **2** on the RCU
Note: Another way for selecting this input is via the Menu.

3.5.2.8 Serial Digital Interface (Optional)



SDI
Serial Digital Interface

3. Installation

Input specifications

SDI input : BNC

SDI output : BNC (=loop through)

typical : 0.8 Vpp

75Ω terminated

output impedance: 75Ω

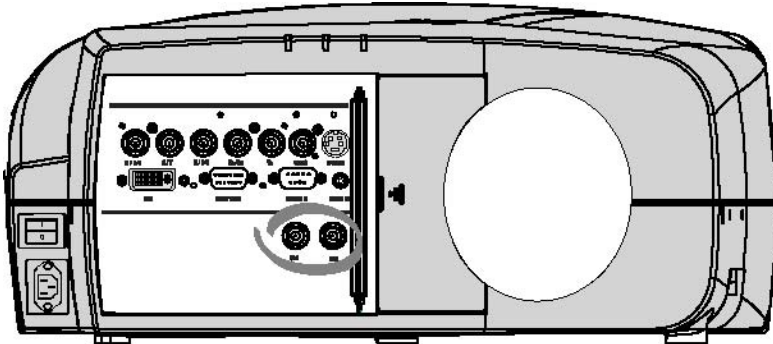

Image 3-17

How to select the SDI input

1. Press 7 on the RCU

Note: Another way for selecting this input is via **Source** on the local keypad or via the Menu.



The SDI is located on Layer3 which is an optional Layer.

3.5.2.9 Audio input/Output (Optional)

Input specification

Typical = 200 mV

Max = 4V_{pp}

Mono/Stereo

Output specification

V_{in} +20dB / -∞ dB

Max = 4 V_{pp}

Mono/Stereo (selectable in menu)

How to select the audio input ?

1. Use the Audio menu (General menu) to link the desired audio input to the desired signal.

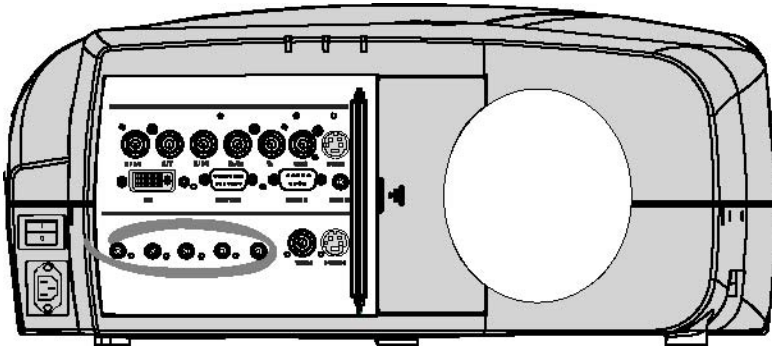

Image 3-18

3.5.2.10 Communications Connections

Overview

- RS232 IN connection

3.5.2.10.1 RS232 IN connection

What can be connected to the RS232 IN connection ?

The RS 232 IN connections allows the projector to communicate with a Computer e.g. IBM PC or Apple Macintosh.

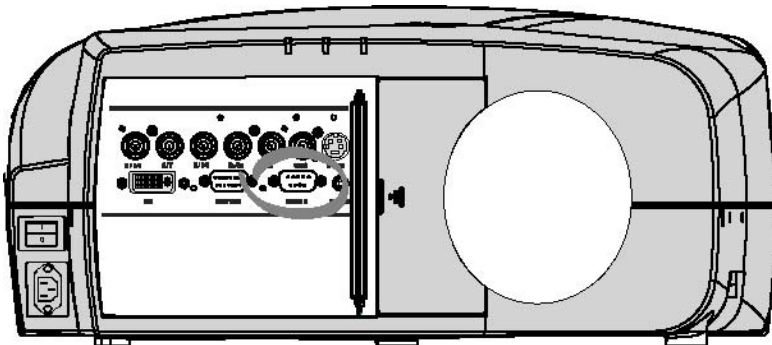

Image 3-19

Applications of the RS232 connection

Remote control:

- easy adjustment of projector via IBM PC (or compatible) or MAC connection.
- address range from 1 to 255
- allow storage of multiple projector configurations and set ups.
- wide range of control possibilities

Data communication: sending data to the projector or copying the data from the projector to the computer



To set up the baudrate of the projector, see the Installation menu

4. SETUP

Overview

- RCU & Local keypad
- Terminology overview
- Switching on
- Setting the RCU address
- Projector address
- Orientation
- Adjusting the lens
- Preferences

4.1 RCU & Local keypad

How controlling the projector ?

The projector can be controlled by the local keypad or by the remote control unit.

Location of the local keypad ?

The local keypad is located on the topside of the projector.

For key overview: "Terminology overview", page 26

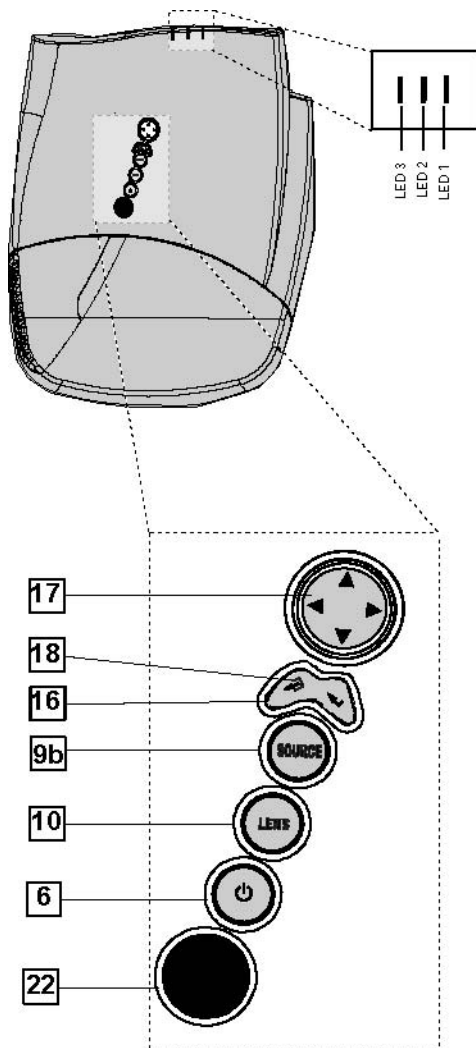

Image 4-1
Local keypad layout

Remote control functions.

This remote control includes a battery powered infrared (IR) transmitter that allows the user to control the projector remotely. This remote control is used for source selection, control, adaptation and set up. It includes automatic storing of picture controls (Brightness, Sharpness...) and settings.

Other functions of the remote control are :

- switching between stand by and operational mode.
- switching to "pause" (blanked picture, full power for immediate restarting)
- direct access to all connected sources.

Diagnose LED's

	Green	Red
LED1	cool down sequence: flickers 60 seconds (120 seconds in case of iQ 400 series) after switching to standby	rescue program (software error)
LED2	only for the versions containing a server: shows when projector is in standby and server is active.	hardware error
LED3	IR acknowledgement	continue : standby flickers : Security = ON

4.2 Terminology overview

Overview

The following table gives an overview of the keys.

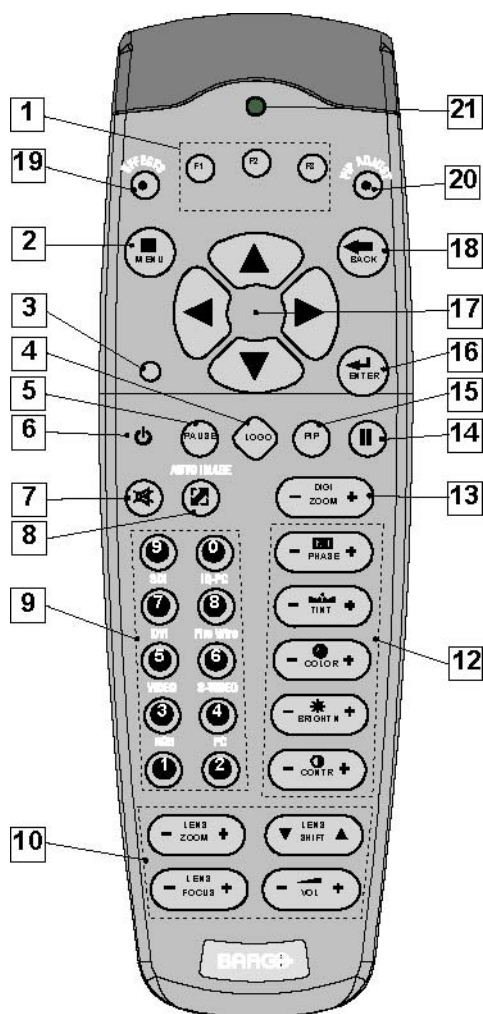

Image 4-2

1	Function keys	user programmable keys with functions for direct access.
2	MENU	Menu key, to enter or exit the Toolbar menu.
3	Address key	(recessed key), to enter the address of the projector (between 0 and 9). Press the recessed address key with a pencil, followed by pressing one digit button between 0 and 9.
4	LOGO key	allows to recall the stored Logo (not in PiP mode)
5	PAUSE	to stop projection for a short time, press 'PAUSE'. The image disappears but full power is retained for immediate restarting.
6	STBY	standby button, to start projector when the power switch is switched on and to switch off the projector without switching off the power switch. Attention : Switching to Standby. When the projector is running and you want to go to standby, press the standby key for 2 seconds.
7	MUTE	to interrupt the sound reproduction (audio = optional).
8	AUTOIMAGE	Auto image, to center the image on the active LCD surface.
9	Digit buttons	direct input selection.
9b	SOURCE button	this button allows to switch through the active (scanned) inputs
10	Lens control	use these buttons to obtain the desired ZOOM, SHIFT, FOCUS.
11	VOL	use this button to obtain the desired sound level (audio = optional)
12	Picture controls	use these buttons to obtain the desired picture analog level.
13	DIGI ZOOM	allows a digital Zoom of a part of the image
14	FREEZ	press to freeze the projected image.
15	PIP	allows to activate the PICTURE IN PICTURE mode

4. Setup

16	ENTER	to confirm an adjustment or selection in the MENU. On the local keypad the ENTER button additionally accesses the PiP window resize function
17	Cursor keys	Cursor Keys on RCU or on the local keypad : to make menu selections or to access the toolbar.
18	BACK	to leave the selected menu or item (go upwards to previous menu).
19	EFFECTS	not yet implemented
20	PIP ADJUST	allows to select a PiP window and change its configuration on screen
21	RC operating indication	lights up when a button on the remote control is pressed. (This is a visual indicator to check the operation of the remote control)
22	IR receiver	IR receiver

Table 4-2



ordernumber RCU: R763794K



Depending on the projectors some functions like LOGO, DIGI ZOOM, PiP, ... are not supported.

4.3 Switching on

How to switch on.

1. Press the power switch to switch on the projector.
 - When '0' is pushed in, the projector is switched off.
 - When '1' is pushed in, the projector is switched on

The projector starts in standby mode, LED3 is red.

Starting image projection.

1. Press **Standby** key once on the local keypad or on the remote control.

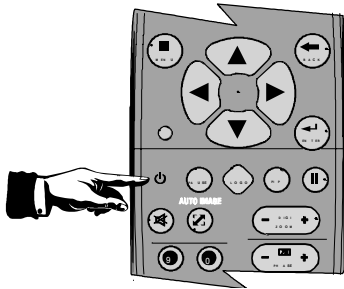

Image 4-3



It may take about 60 seconds before image projection, i.e. no projection until the completion of several operations (software initialization,...).



If the Security mode is enabled, a textbox will be displayed for PIN code entry, see **Security** setting in the **Installation** menu

4.4 Setting the RCU address

What has to be done ?

To allow the communication between the RCU and the projector the RCU has to be programmed with the same address as the projector.

This address must be in the range 0–9.

To know the address of the projector, one can visualize it in projection mode (on screen) as well as in standby mode (shown with the LED's on top cover of the projector).



For more info on addresses see the appendix



At this stage the image projected may happen to be upside down or mirrored, this can be set in the *Installation* menu under *Projector orientation* (see further setting up the projector's orientation).

Displaying the Projector Address in Standby mode

1. Press the **Address** key (recessed key on the RCU) with a pencil.

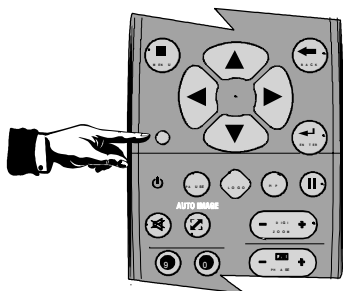

Image 4-4

All the LED's (3) on the top cover of the projector go out.

Then LED1 starts blinking green the number of hundreds. After that LED2 starts blinking the number of tens. Finally LED3 starts blinking green the number of units. If this is done, the original status of the LED's is restored.

Displaying the Projector Address in projection mode

1. Press the **Address** key (recessed key on the RCU) with a pencil.

The projector's address will be displayed on the screen in a text box

Programming the RCU

1. Push the address key If the address is not entered within 5 seconds, the RCU returns to its default address (zero address) and controls then all projectors in the room.
2. Enter the same address with the digit buttons **within 5 seconds** after pushing the address key.

The projector can now be controlled with the RCU.



For example : if the projector address is 3, then press "3" on the RCU to set the RCU's address to match the projector's address.



Common address/Projector address : Beside the projector address, the projector disposes also of a Common address which can be set to "0" or "1" (by default "0").

In other words, an RCU set to address "0" will always control a projector regardless of its projector address (since it uses the common address).

4.5 Projector address

What can be done ?

The projector is shipped with projector address set to "0"

In some cases the projector address must be changed, for example if an unique RCU is used to control 2 or more projectors (independently).

In the OSD menu *Projector Address*, the following addresses can be programmed :

- Projector address: address defined by the user, may be from 0 to 255
0-9 is used for RCU communication, 0-255 being used for RS232 serial communication.
- Common address : address may be 0 or 1

How to change the projector's RC5 address ?

1. Press **MENU** to activate the Tool bar
2. Press → to select the *Installation*
3. Press ↓ to Pull down the *Installation* menu
4. Use ↑ or ↓ to select *Projector address*

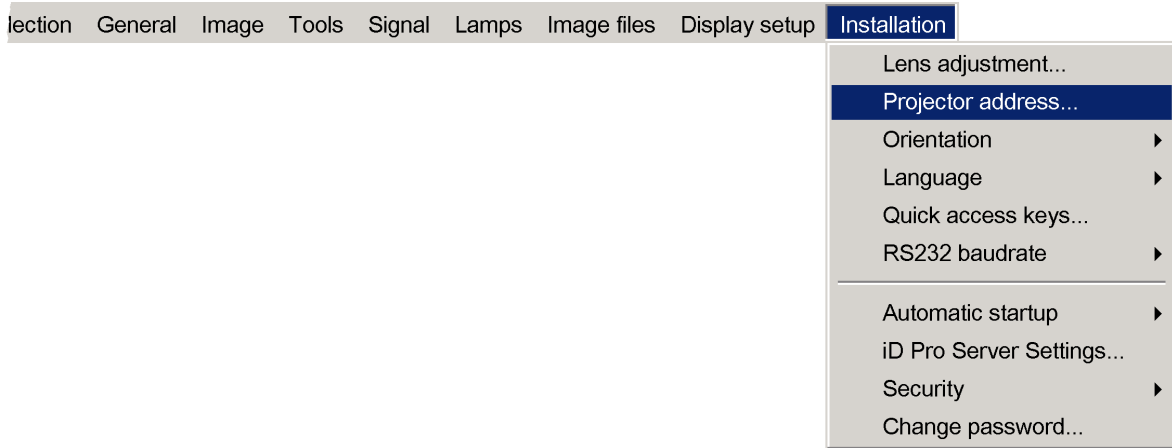

Image 4-5

5. Press **ENTER**

A dialog box appears on the screen.

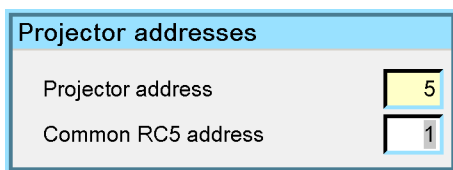

Image 4-6

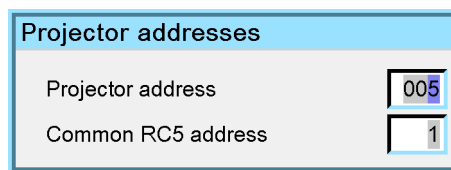

Image 4-7

Entering the new projector address ?

1. Enter the new projector address with the digit keys on the RCU, the local keypad or the cursor keys.



This address must be between 0 and 255.

How to change the common RC5 address ?

1. Press **MENU** to activate the Tool bar
2. Press → to select the *Installation*
3. Press ↓ to Pull down the *Installation* menu
4. Use ↑ or ↓ to select *Projector address*
5. Press **ENTER**

A dialog box appears on the screen.

Entering the new common address ?

1. Enter the new projector address with the digit keys on the RCU, the local keypad or the cursor keys.



This address must be between 0 or 1.

4.6 Orientation

Projector orientations

Depending on how the projector is oriented, the projector's internal settings have to be adapted.

How to change the orientation ?

1. Press **MENU** to activate the Toolbar
2. Press **→** to select the *Installation* item
3. Press **↓** to Pull down the *Installation* menu
4. Use **↑** or **↓** to select *Orientation*
5. Press **→** to pull down the menu
6. Use **↓** or **↑** to select the desired orientation

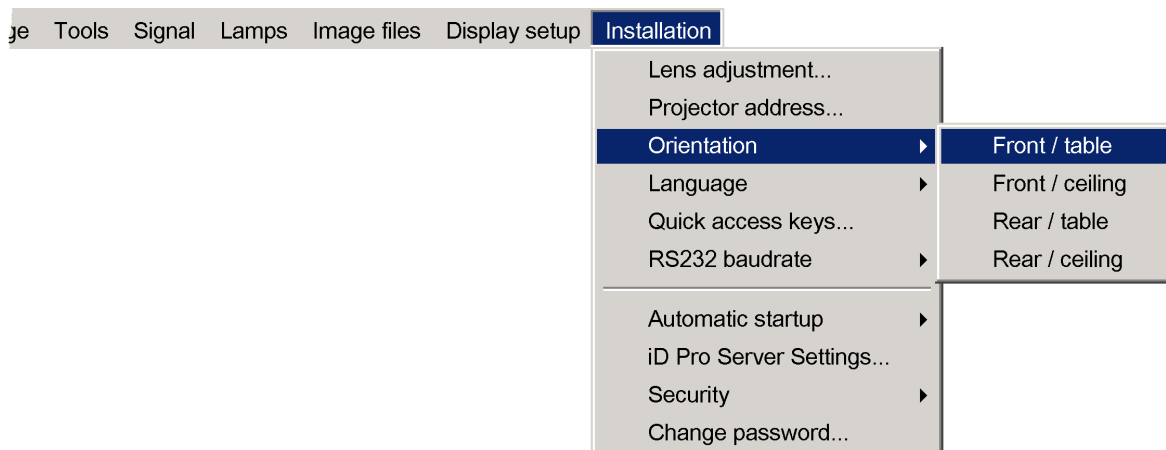

Image 4-8

7. Press **ENTER**

The projection is adapted and a black bullet shows the active configuration.

4.7 Adjusting the lens

What must be done ?

Depending on the projection distance and the lens used, the image may not be at the desired size, position and/or may be out of focus.

The projector will always allow you to shift your image vertically as well as horizontally (when available) to position it on the screen. In addition, motorized lenses will also allow you to Zoom and focus the image.

All these lens parameters can be adjusted using the RCU, the local keypad or in the Installation menu of the projector's OSD.

- Zoom (only for motorized lenses)
- Focus (only for motorized lenses)
- Vertical Shift



The lens can also be adjusted via the dedicated keys on the remote.

How to Zoom/focus or shift via the RCU (or keypad)

1. Press **LENS ZOOM** or **LENS FOCUS** or **LENS SHIFT** on the RCU

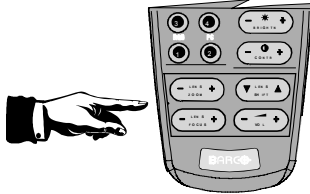

Image 4-9

2. Use the arrow keys to adjust

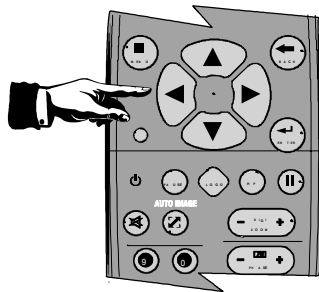

Image 4-10

How to Zoom/focus or shift in the OSD ?

1. Press **MENU** to activate the Tool bar
2. Press → to select the *Installation*
3. Press ↓ to Pull down the *Installation* menu
4. Use ↑ or ↓ to select *Lens adjustments...*

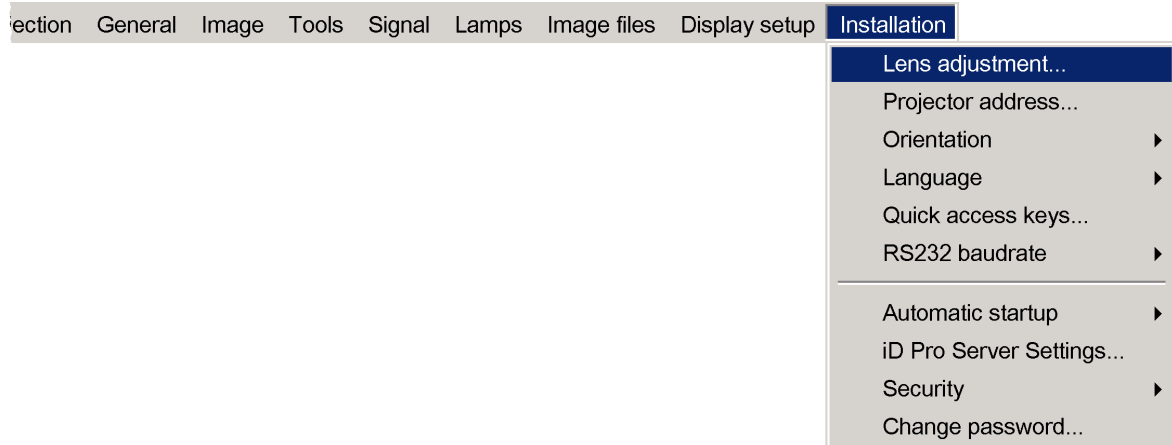

Image 4-11

5. Press **ENTER**

A textbox appears on the screen, follow the instructions.

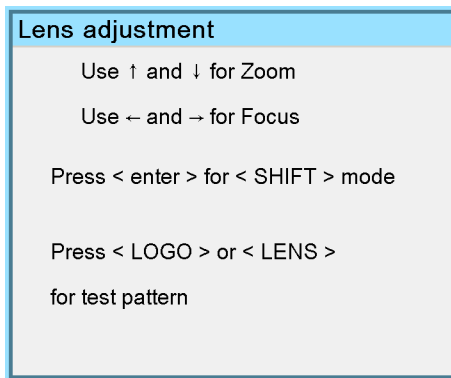

Image 4-12

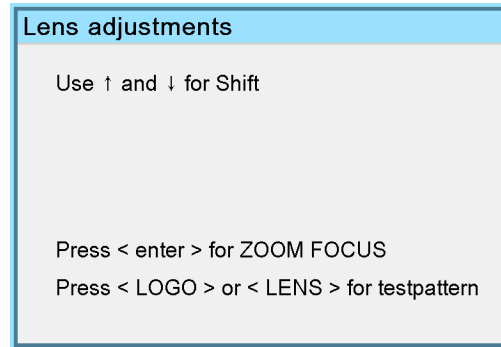

Image 4-13



The use of a sheet of paper held in front of the screen can be useful to determine the focus plane (position for best focus)



Vertical shift range : -120% to 120%

4.8 Preferences

4.8.1 Language

List of languages

The list of selectable languages is depending on the software of the projector.

How to change the Language ?

1. Press **MENU** to activate the Tool bar
2. Press → to select the *Installation* item
3. Press ↓ to Pull down the *Installation* menu
4. Use ↑ or ↓ to select *Language*
5. Press → to pull down the menu
6. Use ↓ or ↑ to select the desired language

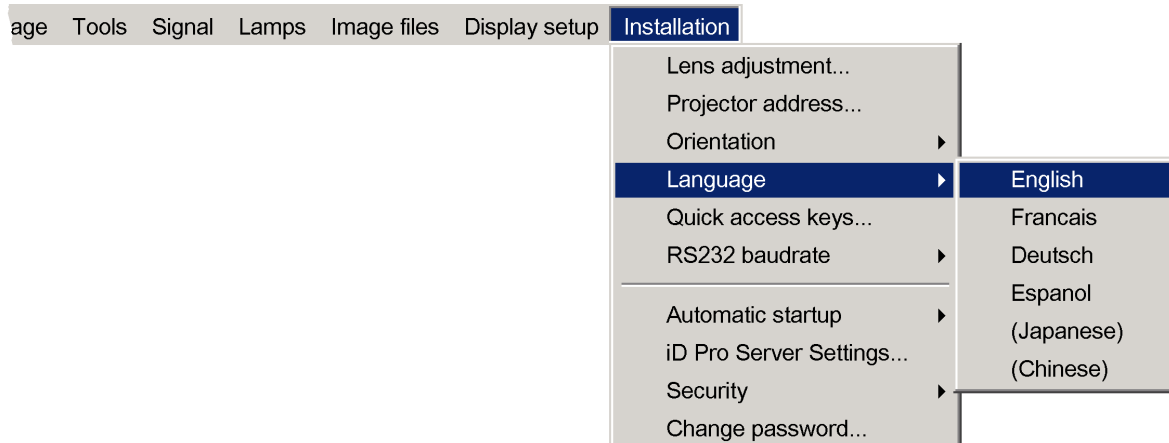

Image 4-14

7. Press **ENTER**

The language is adapted and a black bullet shows the active configuration.

4.8.2 Quick access keys

What can be done ?

The 3 function keys on top of the RCU can be associated with a particular item in one of the menus.

Each function which is not password protected or does not have a key on the RCU can be associated to a function key.

How to get an overview of the quick access keys ?

1. Press **MENU** to activate the Tool bar
2. Press → to select the *Installation*
3. Press ↓ to Pull down the *Installation* menu
4. Use ↑ or ↓ to select *Quick access keys*



Image 4-15

5. Press **ENTER**

A text box appears on the screen.

How to program the quick access keys ?

1. Scroll through the menus to the desired menu item
2. Push the desired function key for 3 seconds

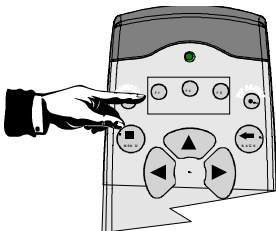

Image 4-16

The menu item is stored in the quick access key



Factory pre-programmed functions

- F1 : color depth
 - F2 : noise reduction
 - F3 : orientation
-

4.8.3 Automatic startup

What can be done ?

The automatic startup allows to bypass the standby state i.e. start up without going in standby state after switching on the projector.

This means that the automatic startup allows immediate restart of the projector after a power failure (breakdown), i.e. without passing through the standby state, by recovering the previous settings (previous source,...).

This function can be disabled if undesired or inadequate for safety reasons, etc.



CAUTION: If the Automatic startup function is enabled one must be aware of the fact that it involves safety precautions

Make sure that the projector (or the operators!) will not be affected by altered environmental conditions when restarting at power resume.

How to enable/disable the Automatic startup?

1. Press **MENU** to activate the Tool bar
2. Press → to select the *Installation* item
3. Press ↓ to Pull down the *Installation* menu
4. Use ↑ or ↓ to select *Automatic startup*
5. Press → to pull down the menu
6. Use ↓ or ↑ to enable/disable the automatic startup

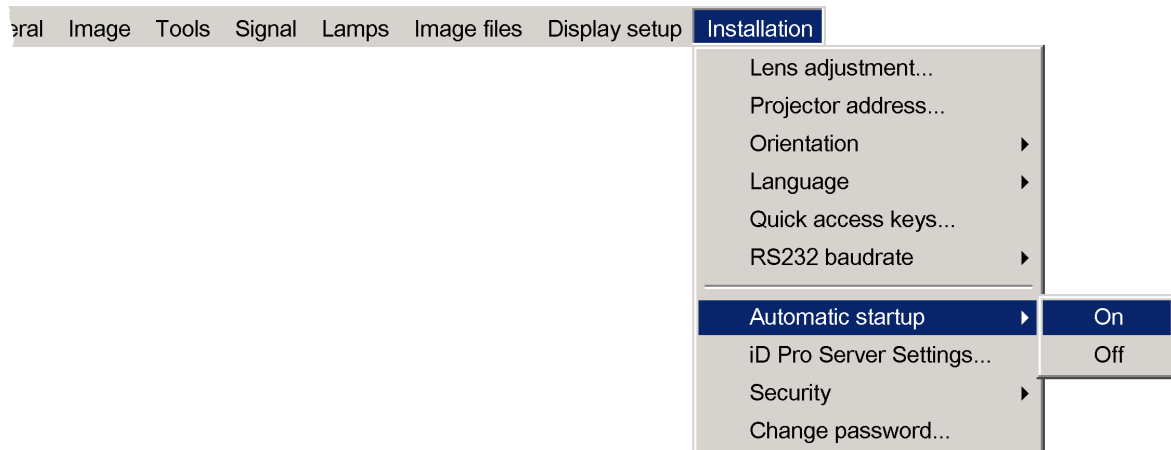

Image 4-17

7. Press **ENTER**

5. GETTING STARTED

5.1 Start up

How to start up the projector ?

1. Press the Standby button on the RCU or the local keypad

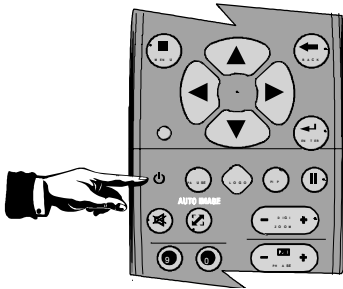

Image 5-1

The last selected source is displayed

5.2 Creating your personal PiP Layout



As an example: the layout to be created must contain :

- one video source : composite video
- one data source : RGBHV

How to create a new layout based on an existing layout ?

1. Select an existing custom layout (non factory) from the *PiP select* menu

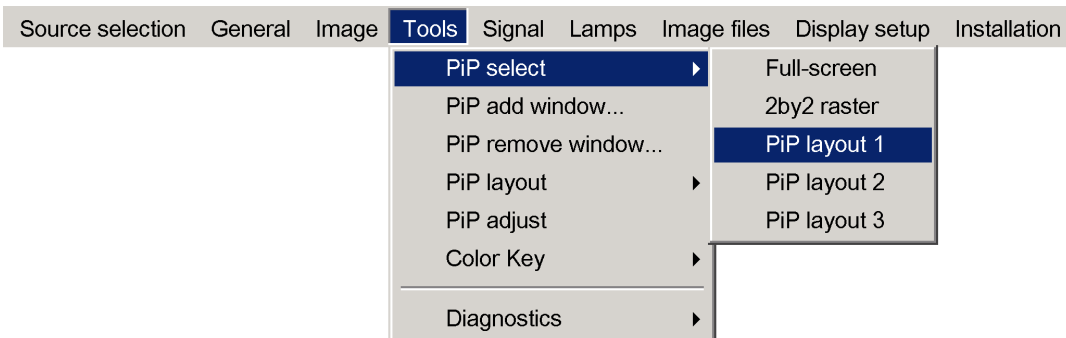

Image 5-2

2. Add the video window from the *PiP add window* menu by selecting the desired composite video source

Note: You can only use one (2 in case of an optional video input) video source i.e. if the layout already contains a video source, it will be impossible to add another (different) video input .

5. Getting started

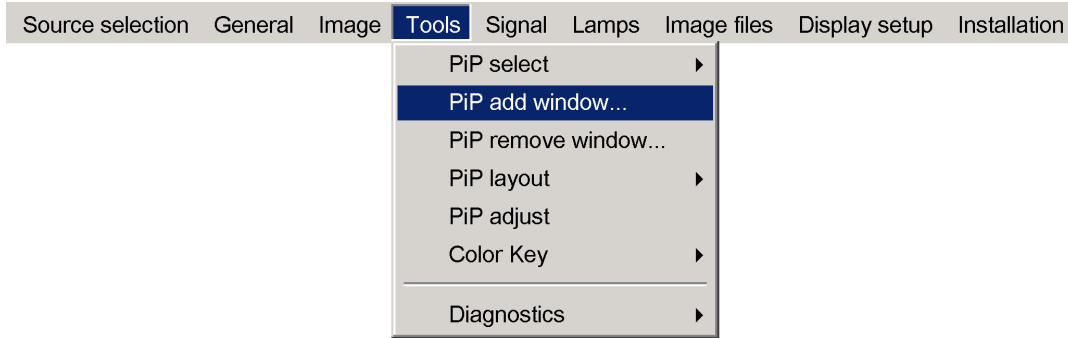

Image 5-3

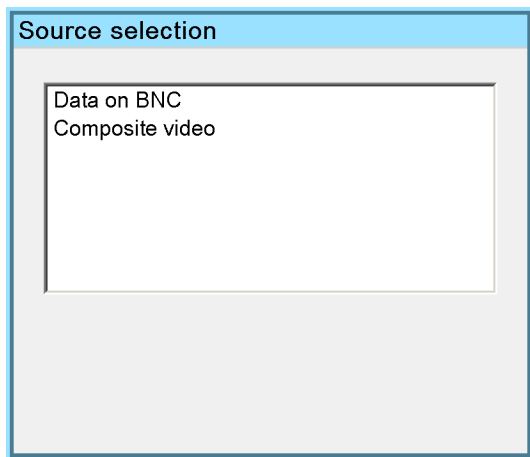

Image 5-4

3. Follow the instruction wizard (size, position, order)
4. Repeat the previous steps to add the RGB source
5. Save the PiP layout in the *PiP layout/Save as* menu by typing a new name

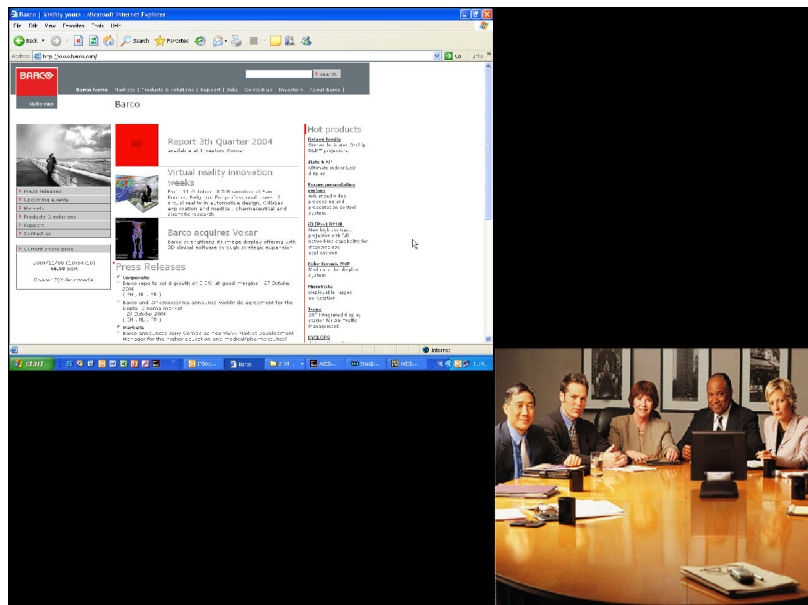

Image 5-5
Video/Data PiP layout



The added source(s) should be displayed with the right settings thanks to Autolmage. If it's not the case (in case of some non standard source specifications) see *Image files* in the Advanced chapter.

5.3 Adjusting the image

How to adjust the image

1. Use the PiP adjust button on the RCU to select the desired window

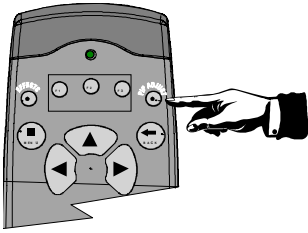

Image 5-6

2. Use the Image setting buttons on the RCU

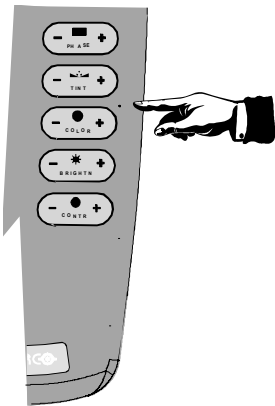

Image 5-7

6. ADVANCED

6.1 Using the Dialog boxes

How to use the dialog boxes ?

Some parameters are modified by means of a dialog box, where selections can be made and/or values can be entered.

The values can be entered in several ways:

Entering numeric values using the numeric keys on the remote control

1. Press **ENTER** to activate the input field.

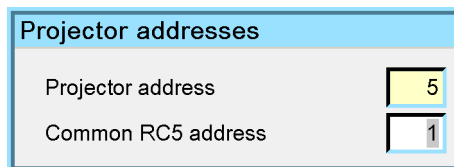

Image 6-1

2. Key in the desired value.

Entering numeric values using the arrow keys on the remote control

1. Press **ENTER** to activate the input field.
2. Press ← or → to select the digit to be changed.

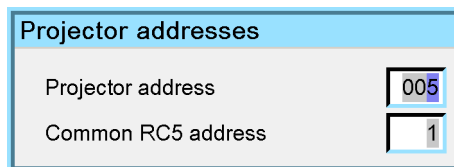

Image 6-2

3. Press ↓ or ↑ to increase or decrease the value.

Entering numeric values using the arrow keys on the local keypad

1. Press **ENTER** to activate the input field.
2. Press ← or → to select the digit to be changed.
3. Press ↓ or ↑ to increase or decrease the value.



To confirm the changes always press **ENTER**.

Use ↓ or ↑ to browse between the different fields.



In some cases an alphanumeric value (file name, ...) has to be entered. Use ↑ or ↓ to scroll through the character values once the input field is activated.

Following characters can be browsed in this particular order:

Decimal scroll list: 0123456789

Signed decimal scroll list: 0123456789-

ASCII scroll list: ABCDEFGHIJKLMNOPQRSTUVWXYZ0123456789+*/&@#.;,abcdefghijklmnopqrstuvwxyz

6.2 Source Selection

Overview

- Source selection
- Composite Video
- S-Video

6.2.1 Source selection

Selecting a source

The Source selection menu allows to select one of the different sources. Another method to select an input source is via the remote control using the numeric keys or by using the local keypad.



When selecting a source with a different resolution (and/or aspect ratio) than the projector's resolution (and/or aspect ratio), the source can be shown in its native resolution or can be re-scaled to the projector's resolution, the latter case brings of course some loss of quality.

For more info on resolution match see the Show native resolution function in the *Image* menu.

How to select a source ?

1. Press **MENU** to activate the Tool bar
2. Press ↓ to Pull down the Source Selection menu

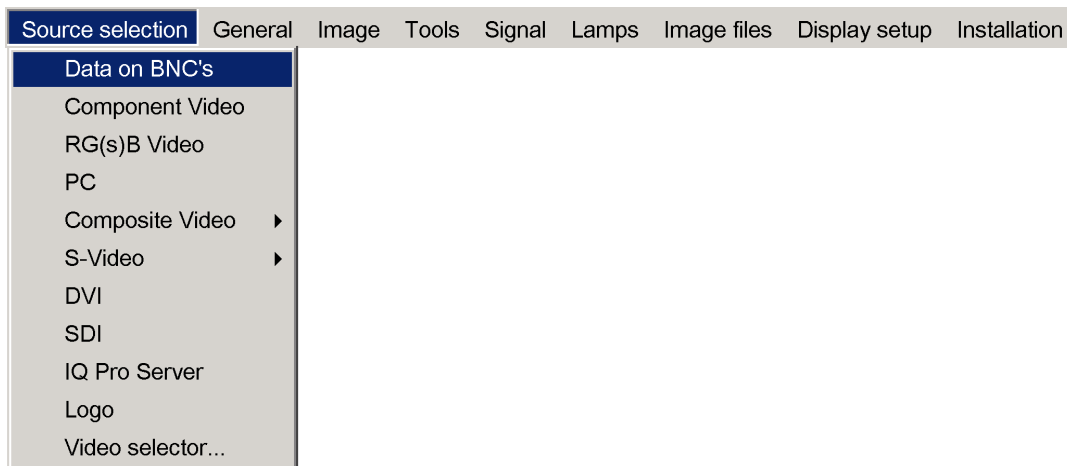

Image 6-3

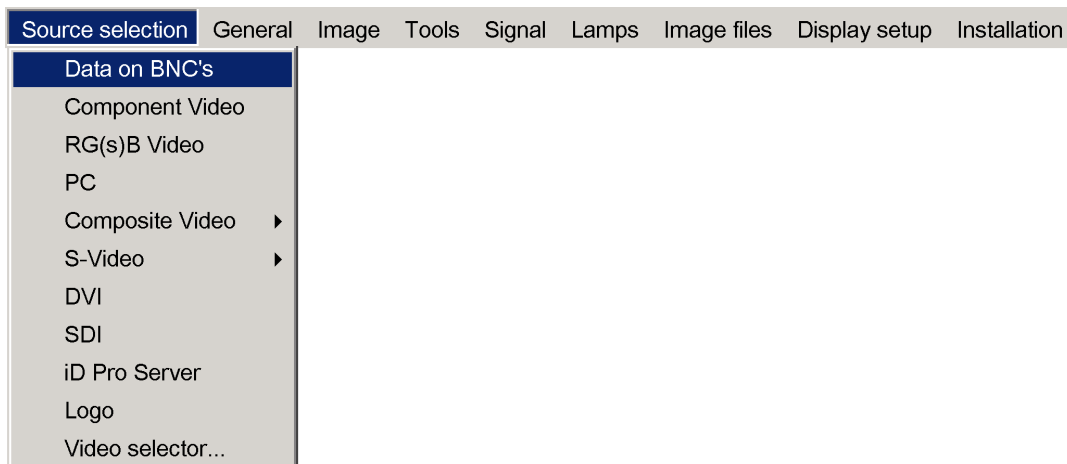

Image 6-4

3. Use ↑ or ↓ to select one of the different sources (Press → to Pull down if the item has a submenu)
4. Press **ENTER** to confirm your choice

On the screen appears now the selected source.



The Barco logo on the menu indicates the presence of a signal, the digit indicates the shortcut key on the RCU.

The 3 first sources (Data on BNC's, Component Video & RG(s)B) refer to the 5-cable input, the position of the indication "1" will always show which BNC configuration is selected.

When to select "Data on BNC's"

Select Data on BNC's when a data signal is connected to the BNC's

When to select "Component video" ?

Select Component video when a video signal of the type (R-Y/Y/B-Y) is connected on the BNC's.

When to select RG_sB Video ?

Select RG_sB Video when an RGB video signal (15 KhZ) with Sync on green or sync on H is presented on the BNC's.

This signal is routed to the video circuit and is projected in a Video Window.

6.2.2 Composite Video

How to select one of the 7 composite video inputs ?

1. Press **MENU** to activate the Tool bar
2. Press ↓ to Pull down the Source Selection menu
3. Use ↑ or ↓ to select *Composite video*
4. Press → to Pull down the submenu
5. Use ↑ or ↓ to select one of the different video inputs

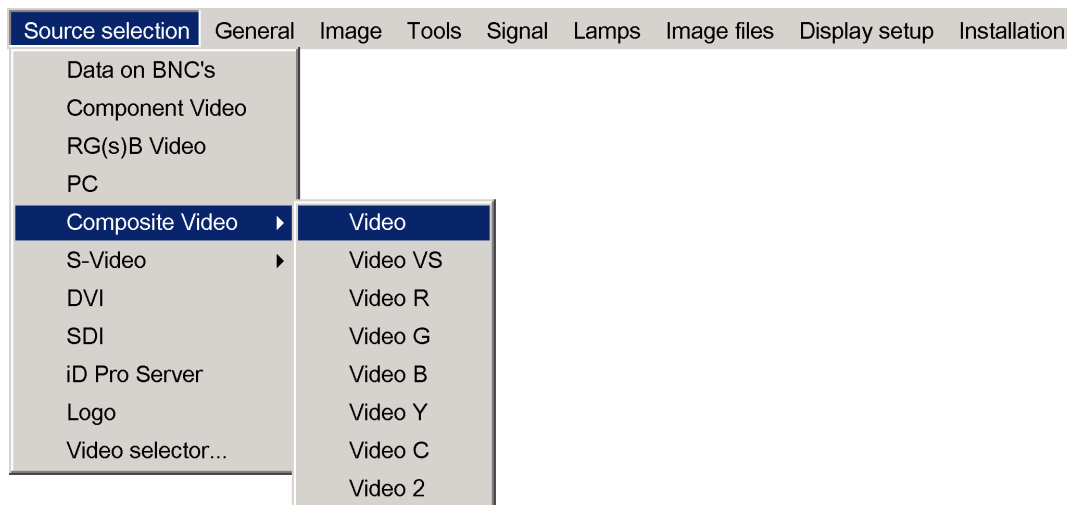

Image 6-5

Note: Video2 is an optional Video input and is only displayed in case the optional Video/Audio layer is installed.

If the extended mode is disabled, the submenu contains only 1 selection (2 selections if the Audio & Video option is installed).

6. Press **ENTER** to confirm your choice

A white bullet indicates the selected composite video source which now appears on the screen.

Adjustments on a Composite video signal

The projectors allows different adjustments on a composite video signal. Depending on the type of signal (NTSC /PAL) the terminology may differ :

- Contrast
- Brightness
- Color : adjusts the level of color saturation in a PAL signal
- Tint : adjusts the level of color saturation in an NTSC signal
- AGC: Automatic Gain Control



The composite video sources can also be selected using the video selector or via the dedicated key 3 on the RCU. Key 3 allows to browse through the active video inputs when the extended mode is checked in Video Selector..

6.2.3 S-Video

When

Select the S-Video input when in presence of a video signal also called S-VHS signal.

An S-Video signal is available on the Mini-Din connector of a camera, VCR or DVD player.

How to select one of the 3 S-Video inputs ?

1. Press **MENU** to activate the Toolbar
2. Press ↓ to Pull down the Source Selection menu
3. Use ↑ or ↓ to select *S-Video*
4. Press → to Pull down the submenu
5. Use ↑ or ↓ to select one of the different video inputs

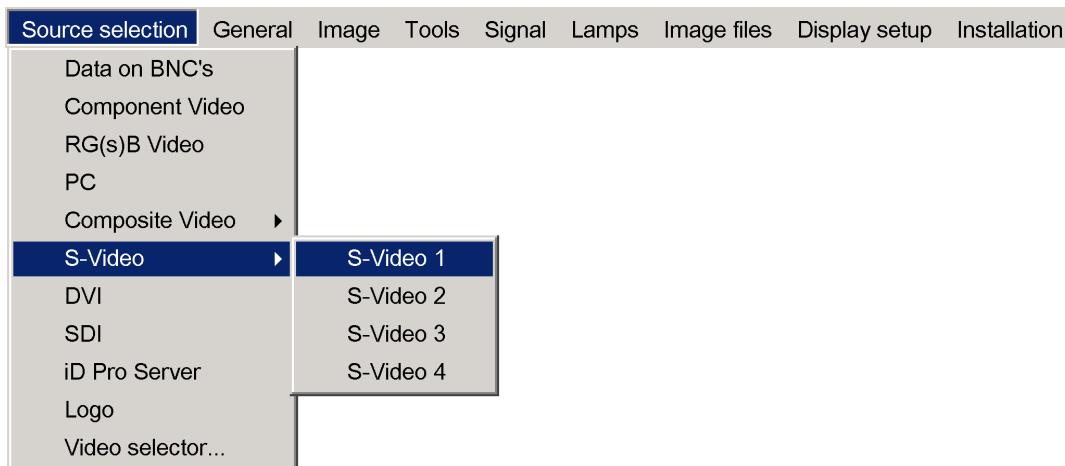

Image 6-6

Note: *S-Video4 is an optional Video input and is only displayed in case the optional Video/Audio layer is installed*

If the extended mode is disabled, the submenu contains only 1 selection (2 selections if the Audio & Video option is installed).

6. Press **ENTER** to confirm your choice

A white bullet indicates the selected video source which now appears on the screen.



The S-Video sources can also be selected using the video selector or via the dedicated key 4 on the RCU. Key 4 allows to browse through the active S-Video inputs when the extended mode is checked in Video Selector.

6.3 General menu

Overview

- Pause
- Freeze
- Standby Timer
- Audio (Optional)
- Identification

6.3.1 Pause

Interrupting the image projection

With the Pause function, the image projection can be stopped, the projector remains with full power for immediate restart.

How to interrupt the image projection ?

1. Press **MENU** to activate the Tool bar
2. Press → to select *General*
3. Press ↓ to Pull down the General menu
4. Use ↑ or ↓ to select *Pause*

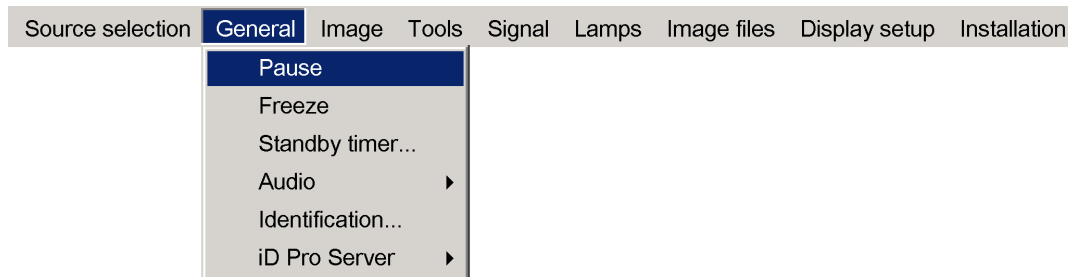

Image 6-7

5. Press **ENTER** to activate the Pause function
A brief sound indicates that the shutter has been activated.



The image projection can also be interrupted using the **PAUSE** key on the RCU.
To restart the image : press **PAUSE**

6.3.2 Freeze

Freezing the image

With the Freeze function, the image can be frozen.

To restart the image, reuse the Freeze function or press the **FREEZE** button on the remote.

How to freeze the image ?

1. Press **MENU** to activate the Tool bar
2. Press → to select *General*
3. Press ↓ to Pull down the General menu
4. Use ↑ or ↓ to select *Freeze*

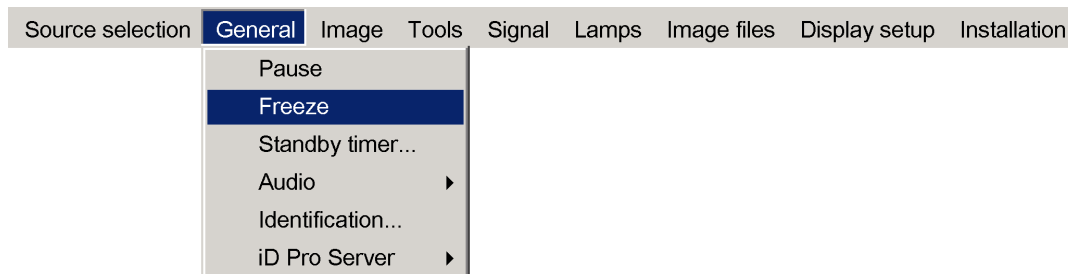

Image 6-8

5. Press **ENTER** to activate the Freeze function



The image can also be frozen using the **FREEZE** key on the RCU

6.3.3 Standby Timer

Purpose of the Standby Timer

If there is no signal, and the standby timer is enabled, a dialogbox is displayed and the projector will shut down after a determined time.

The countdown time can be set in a dialog box in a range from 180 to 3600 seconds (default value = 300). The Timer can also be disabled.

How to enable the timer ?

1. Press **MENU** to activate the Tool bar
2. Press **→** to select *General*
3. Press **↓** to Pull down the General menu
4. Use **↑** or **↓** to select *Standby Timer*

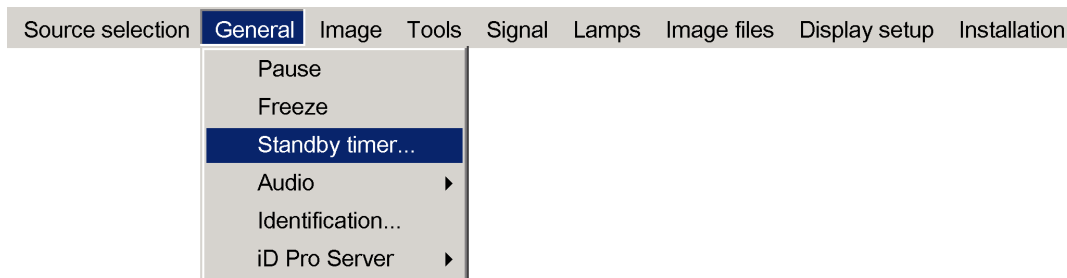

Image 6-9

5. Press **ENTER** to activate the function
On the screen appears a dialogbox

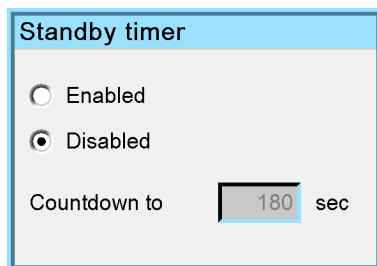

Image 6-10

6. Use **↑** or **↓** to select *Enabled*, a box surrounds the selected item, press **ENTER** to activate
7. Use **↑** or **↓** to browse to the input field
8. Use **←** or **→**, the numeric keys on the remote or the keypad to change the countdown setting
9. Press **MENU** or **BACK** to exit or to go back to the previous menu

6.3.4 Audio (Optional)

Overview

- Audio Setup
- Audio Settings

6.3.4.1 Audio Setup

What can be done ?

Layer 3 allows the input of 4 audio signals, each of them can be linked to the corresponding (video or data) source signal. it is also possible to link multiple audio signals to one video (or data) source signal, this can be useful in case of teleconferencing.

The configuration has to be done in the Audio Setup menu

Starting the Audio Setup menu

1. Press **MENU** to activate the Tool bar
2. Press **→** to select *General*

3. Press ↓ to Pull down the General menu
4. Use ↑ or ↓ to select *Audio setup*

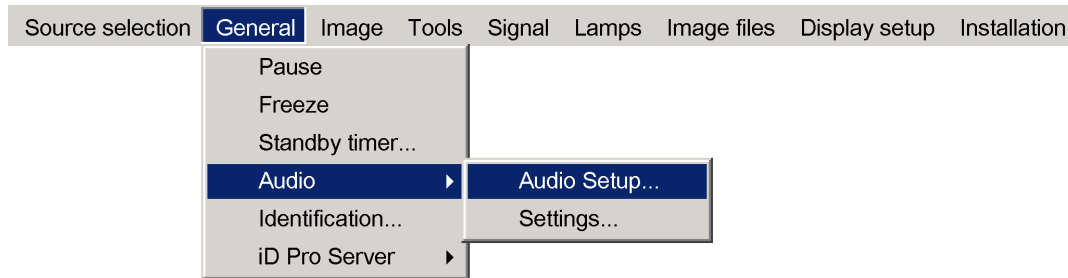

Image 6-11

5. Press **ENTER**
A dialog box is displayed

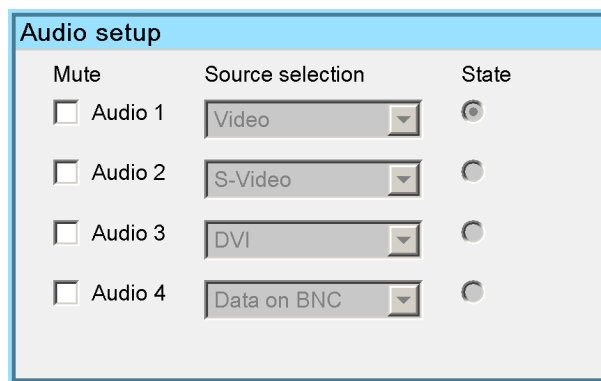

Image 6-12

- LED is red : audio input is mute
- LED is green : input is active (linked image source is selected)
- LED is orange : image source is not selected

How to mute an Audio channel ?

1. use the arrow keys to select the desired mute box
2. Press **ENTER**

How to link an audio input to a source ?

1. use the arrows to select the desired scroll box
2. Press **ENTER** to open the scroll box
3. use ↑ or ↓ to select the source
4. Press **ENTER**



When the source switching mode is the fade in/out mode, the audio switching will also be done using a fade in/out effect.

6.3.4.2 Audio Settings

Audio Settings

1. Press **MENU** to activate the Tool bar
2. Press → to select *General*
3. Press ↓ to Pull down the General menu
4. Use ↑ or ↓ to select *Audio setup*

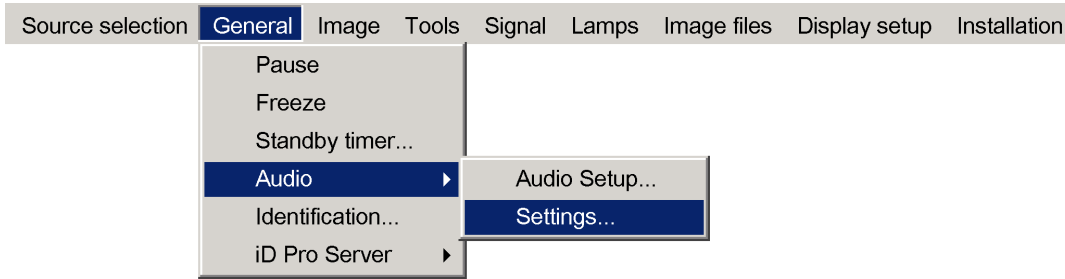

Image 6-13

5. Press **ENTER**

A dialog box is displayed

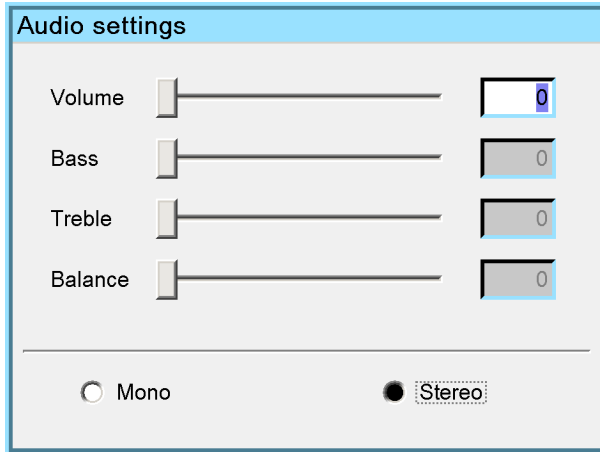

Image 6-14

6. Use the arrow keys to select and change the settings

Note: The default value for the volume is 43, this corresponds to a gain factor of 1 (volume in = volume out).

6.3.5 Identification

The projector's identification screen

The identification screen displays the projector's main characteristics

How to display the identification screen ?

1. Press **MENU** to activate the Tool bar
2. Press → to select *General*
3. Press ↓ to Pull down the General menu
4. Use ↑ or ↓ to select *Identification*

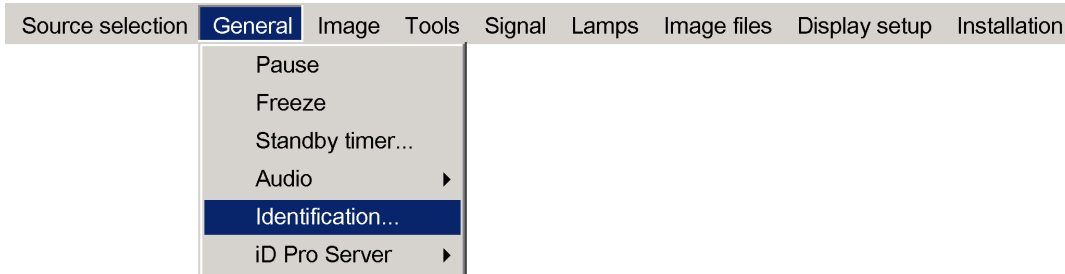

Image 6-15

5. Press **ENTER** to activate the function

On the screen appears a text box.

In this case the projector is an iDR500

Identification	
Type	iDR500
Address	2
Software	01.02
RS232 baudrate	115200
Serial number	6001758

Image 6-16

6. Press **MENU** or **BACK** to exit or to go back to the previous menu

6.4 Image menu

Overview

- Settings
- Aspect ratio
- Show native resolution
- Keystone
- Color temperature
- Filmmode detection (video only)
- White peaking
- Dynacolor™
- Blanking
- Input balance
- AGC on Video
- Manual Gain Control

6.4.1 Settings

Overview

- Contrast
- Brightness
- Color
- Tint (hue)
- Sharpness
- Gamma
- Phase
- Noise reduction

What can be done ?

Correct image settings are important for a good image reproduction. The image settings are made through a dialog box with a scroll bar. Minimal, maximal and actual values are indicated. These settings can also be done directly via the RCU's dedicated buttons, except for the sharpness.

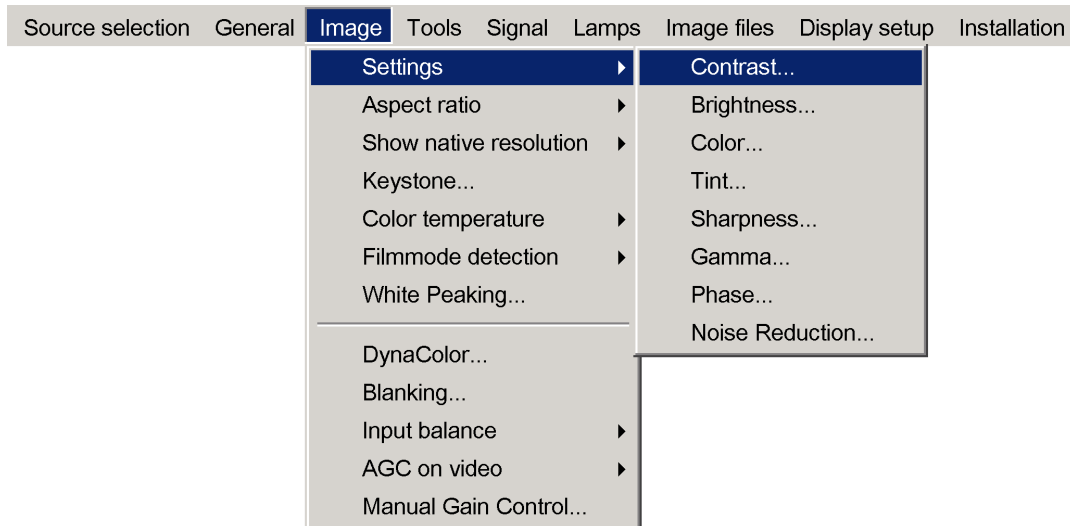

Image 6-17

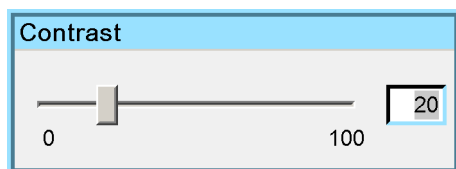

Image 6-18

6.4.1.1 Contrast

Contrast adjustment

Adjust the contrast to "brighten" the white parts of the image.



It is recommended to adjust the brightness before adjusting the contrast.

How to change the contrast

1. Press **MENU** to activate the Toolbar
2. Press **→** to select the *Image* item
3. Press **↓** to Pull down the *Image* menu
4. Use **↑** or **↓** to select *settings*
5. Press **→** to pull down the menu
6. Use **↑** or **↓** to select *Contrast*
7. Press **ENTER**

On the screen appears now a sliderbox

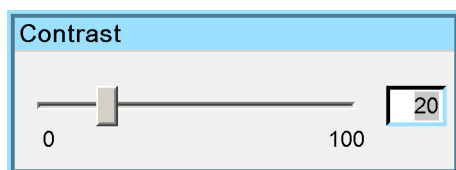

Image 6-19

8. Use **←** or **→**, the numeric keys on the remote, or the keypad to change the contrast

6.4.1.2 Brightness

Brightness adjustment

Adjusting the brightness will affect the dark areas of the image. Increase the brightness to "lighten" up the parts that are too dark.

How to change the Brightness ?

1. Press **MENU** to activate the Toolbar
2. Press → to select the *Image* item
3. Press ↓ to Pull down the *Image* menu
4. Use ↑ or ↓ to select *settings*
5. Press → to pull down the menu
6. Use ↓ or ↑ to select *Brightness*
7. Press **ENTER**

On the screen appears now a sliderbox

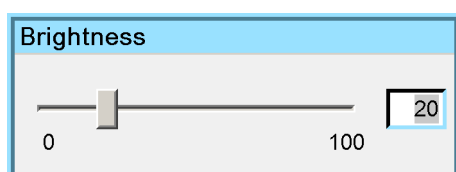

Image 6-20

8. Use ← or → , the numeric keys on the remote, or the keypad to change the Brightness

6.4.1.3 Color

Color adjustment

Adjust the color to obtain more or less saturated colors.

How to change the Color ?

1. Press **MENU** to activate the Toolbar
2. Press → to select the *Image* item
3. Press ↓ to Pull down the *Image* menu
4. Use ↑ or ↓ to select *settings*
5. Press → to pull down the menu
6. Use ↓ or ↑ to select *Color*
7. Press **ENTER**

On the screen appears now a sliderbox

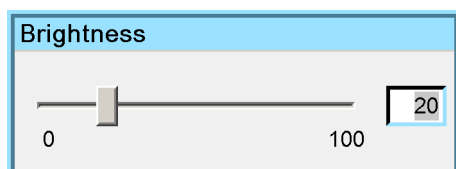

Image 6-21

8. Use ← or → , the numeric keys on the remote, or the keypad to change the Color

6.4.1.4 Tint (hue)

How to change the Tint ?

1. Press **MENU** to activate the Toolbar
2. Press → to select the *Image* item
3. Press ↓ to Pull down the *Image* menu
4. Use ↑ or ↓ to select *settings*
5. Press → to pull down the menu

6. Use ↓ or ↑ to select *Tint*
7. Press **ENTER**
On the screen appears now a sliderbox
8. Use ← or → , the numeric keys on the remote, or the keypad to change the Tint

6.4.1.5 Sharpness

How to change the sharpness ?

1. Press **MENU** to activate the Toolbar
2. Press → to select the *Image* item
3. Press ↓ to Pull down the *Image* menu
4. Use ↑ or ↓ to select *settings*
5. Press → to pull down the menu
6. Use ↓ or ↑ to select *sharpness*
7. Press **ENTER**
On the screen appears now a sliderbox
8. Use ← or → , the numeric keys on the remote, or the keypad to change the sharpness

6.4.1.6 Gamma

How to change the Gamma

1. Press **MENU** to activate the Toolbar
2. Press → to select the *Image* item
3. Press ↓ to Pull down the *Image* menu
4. Use ↑ or ↓ to select *settings*
5. Press → to pull down the menu
6. Use ↓ or ↑ to select *Gamma*
7. Press **ENTER**
On the screen appears now a sliderbox
8. Use ← or → , the numeric keys on the remote, or the keypad to change the Gamma

6.4.1.7 Phase

Phase adjustment

A bad phase adjustment will result in bad transitions and sometimes noise (text can end to be unclear).

How to change the Phase ?

1. Press **MENU** to activate the Toolbar
2. Press → to select the *Image* item
3. Press ↓ to Pull down the *Image* menu
4. Use ↑ or ↓ to select *settings*
5. Press → to pull down the menu
6. Use ↓ or ↑ to select *Phase*
7. Press **ENTER**

On the screen appears now a sliderbox

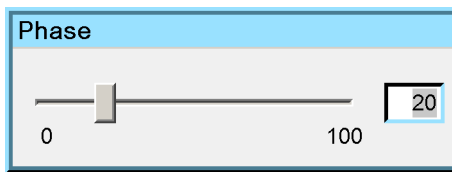

Image 6-22

8. Use ← or → , the numeric keys on the remote, or the keypad to change the Phase

6.4.1.8 Noise reduction

How to change the Noise reduction ?

1. Press **MENU** to activate the Toolbar
2. Press → to select the *Image* item
3. Press ↓ to Pull down the *Image* menu
4. Use ↑ or ↓ to select *settings*
5. Press → to pull down the menu
6. Use ↓ or ↑ to select *Noise reduction*
7. Press **ENTER**

On the screen appears now a sliderbox

8. Use ← or → , the numeric keys on the remote, or the keypad to change the Noise reduction setting.

6.4.2 Aspect ratio

Aspect ratios

The standard aspect ratio used in broadcast television is the 4:3 ratio. However, most of the DVD sources use nowadays the widescreen 16:9 or even the cinemascope 2.35:1 aspect ratio.

Some DVD sources may even use the anamorphic 16:9 or anamorphic 2.35:1 to take advantage of the higher vertical resolution offered by the 4:3 ratio. The "anamorphic" term means that the original widescreen image is squeezed in order to fit the 4:3 aspect ratio.

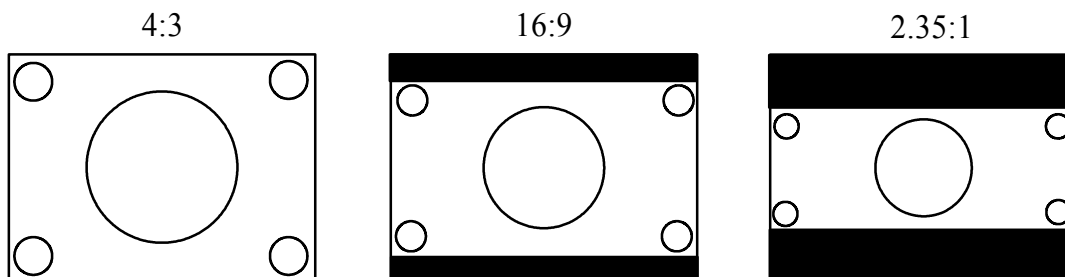

Image 6-23

Common non- anamorphic aspect ratios in DVD sources

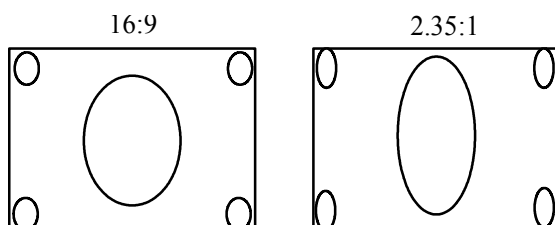

Image 6-24

Anamorphic aspect ratios in DVD sources

What can be done ?

The aspect ratio setting forces the projector to project an image using a defined aspect ratio :

6. Advanced

- 4:3
- 16:9
- 5:4
- Auto



The settings do not refer to the aspect ratio of the source !

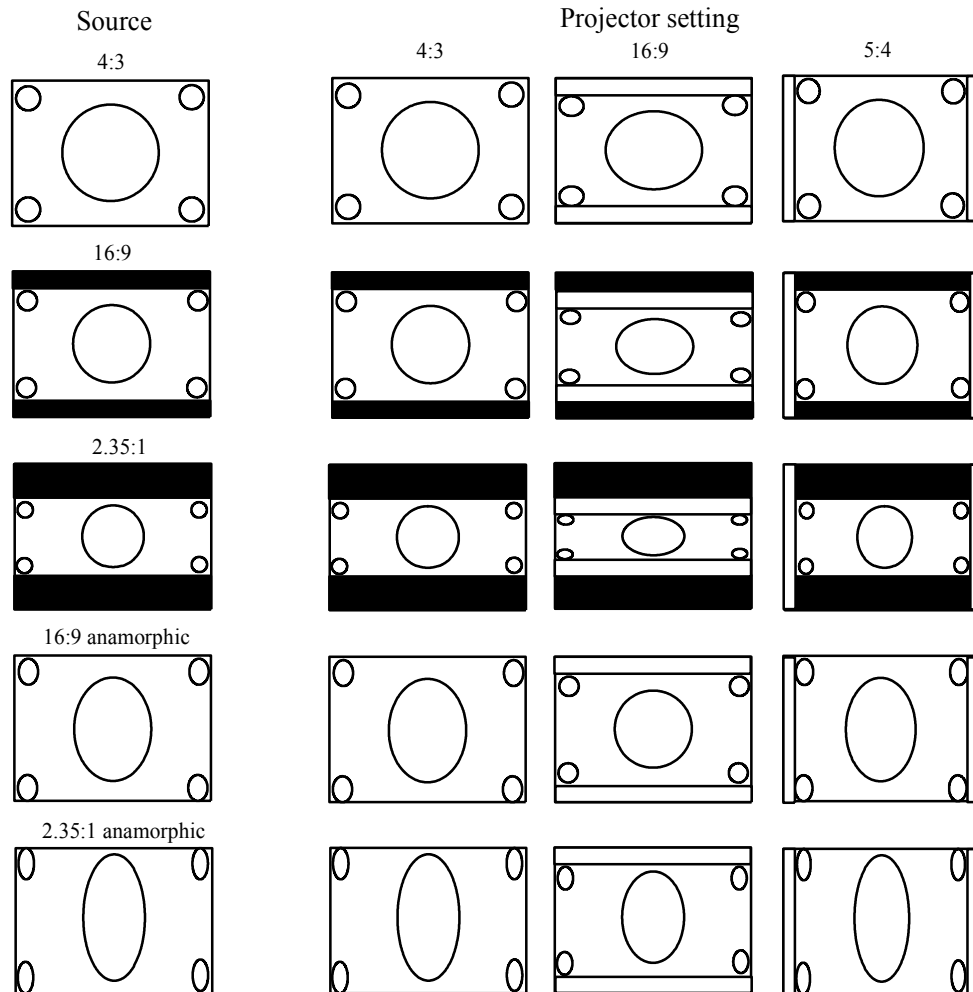

Image 6-25
Possible aspect ratio settings and their effect on different sources in the iQ.

We can conclude that the thumb rule for DVD projection is to always leave the projector in 4:3 format except when dealing with anamorphic sources where the 16:9 setting allows the best reproduction.

The Auto function calculates an aspect ratio based on the information stored in the image files.



Selecting Auto in case of a Video source may shrink the image horizontally

How to change the Aspect ratio ?

1. Press **MENU** to activate the Tool bar
2. Press **→** to select *Image*
3. Press **↓** to Pull down the *Image* menu

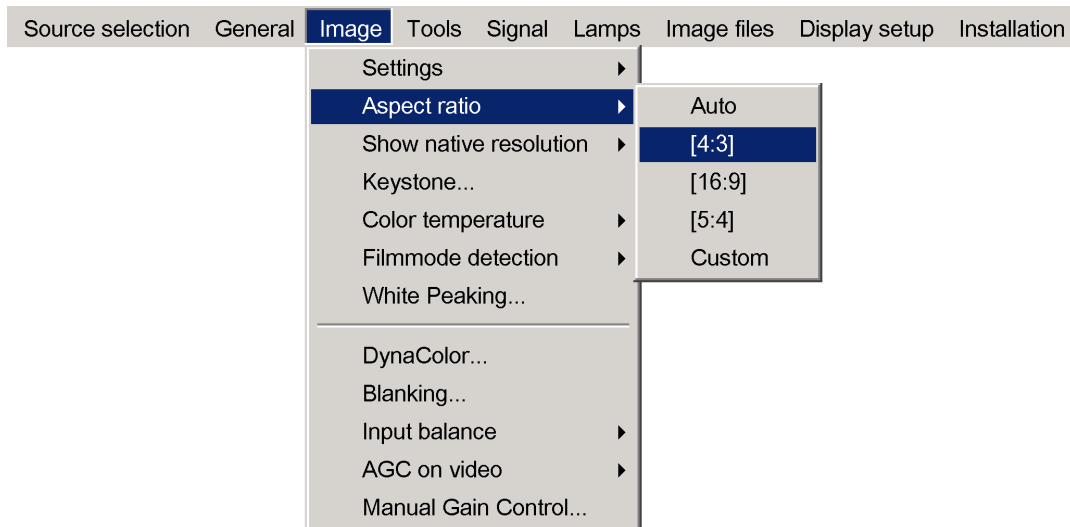

Image 6-26

4. Use ↑ or ↓ to select *Aspect ratio*
5. Use → open the *Aspect ratio* menu
6. Use ↑ or ↓ to select the desired ratio
7. Press **ENTER** to confirm



The aspect ratio settings are greyed out in case the *Show native resolution* or the *Full screen representation* setting is enabled.

How to set a custom Aspect ratio ?

1. Press **MENU** to activate the Tool bar
2. Press → to select *Image*
3. Press ↓ to Pull down the *Image* menu
4. Use ↑ or ↓ to select *Aspect ratio*
5. Use → open the *Aspect ratio* menu
6. Use ↑ or ↓ to select *Custom*
7. Press **ENTER** to confirm

A dialog box is displayed

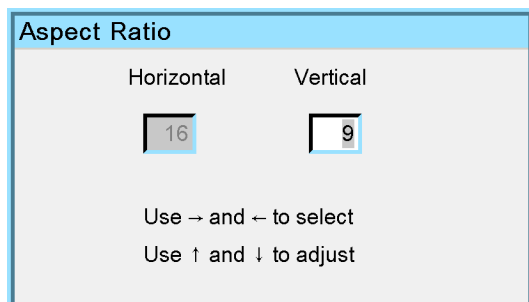

Image 6-27

8. Enter the values for width and height of the image
The image aspect ratio is updated.

6.4.3 Show native resolution



Reality(SXGA+)

Native resolution of the LCD panels = 1400 x 1050 pixels (4:3)

What can be done ?

The aim here is to always show the resolution of the source independently of the resolution of the LCD panels. This way better image reproduction is obtained since no up or down scaling is done on the source.

Note that native resolution refers here to the source and does thus only have sense when handling data sources (greyed out for video sources).

Depending on the type of projector the “show native resolution” function will handle the sources as follows:

Source			Projected image		
Name	Ratio	Resolution	Ratio	Resolution	Display
xga	4:3	1024x768	4:3	1024x768	image centered +side blanked
sxga	5:4	1280x1024	5:4	1280x1024	image centered +side blanked
sxga+	4:3	1400x1050	4:3	1400x1050	image centered
uxga	4:3	1600x1200	4:3	1600x1200	scroll image

Table 6-1
Show native resolution = ON



The **Full screen representation** function on the other hand forces to use the complete native resolution of the LCD panels.

How to enable the “Show native resolution” function?

1. Press **MENU** to activate the Tool bar
2. Press → to select the *Image* item
3. Press ↓ to Pull down the *Image* menu
4. Use ↑ or ↓ to select *Show native resolution*

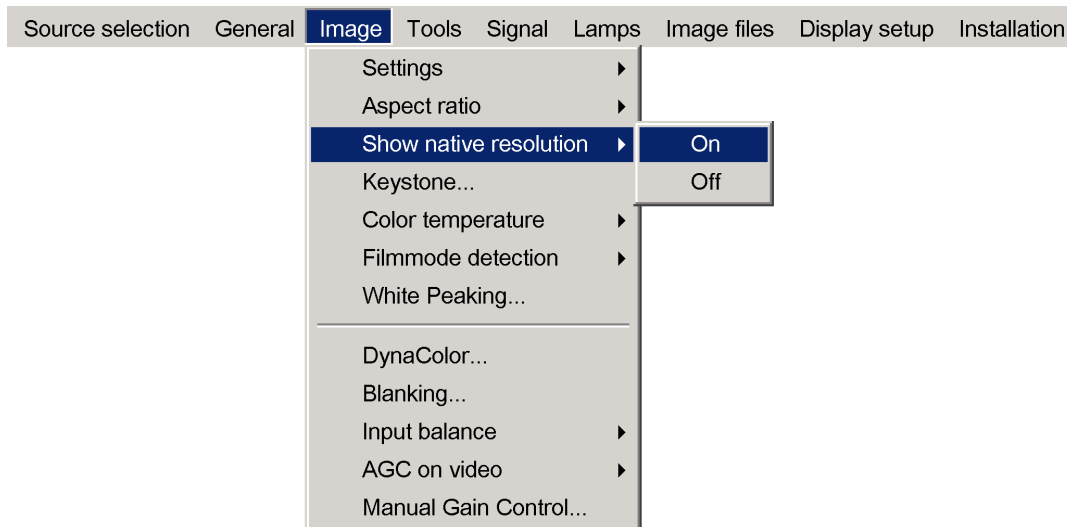

Image 6-28

5. Press → to pull down the menu
6. Use ↓ or ↑ to select *On*
7. Press **ENTER**

A white bullet shows the selection



The default mode is used if the *Show native resolution* and the *Full screen representation* are off.

The default mode shows always the native ratio and forces the native resolution of the panels (part of the image blanked where needed)



When show native resolution is ON and the resolution of the source is higher than the panel resolution , use the arrow keys to scroll through the image (pan).

6.4.4 Keystone

What can be done ?

The Keystone adjustment is used to align the image, this can be necessary when projecting under a non standard angle

How to perform a Keystone correction ?

1. Press **MENU** to activate the Tool bar
2. Press **→** to select *Image*
3. Press **↓** to Pull down the *Image* menu
4. Use **↑** or **↓** to select *Keystone*

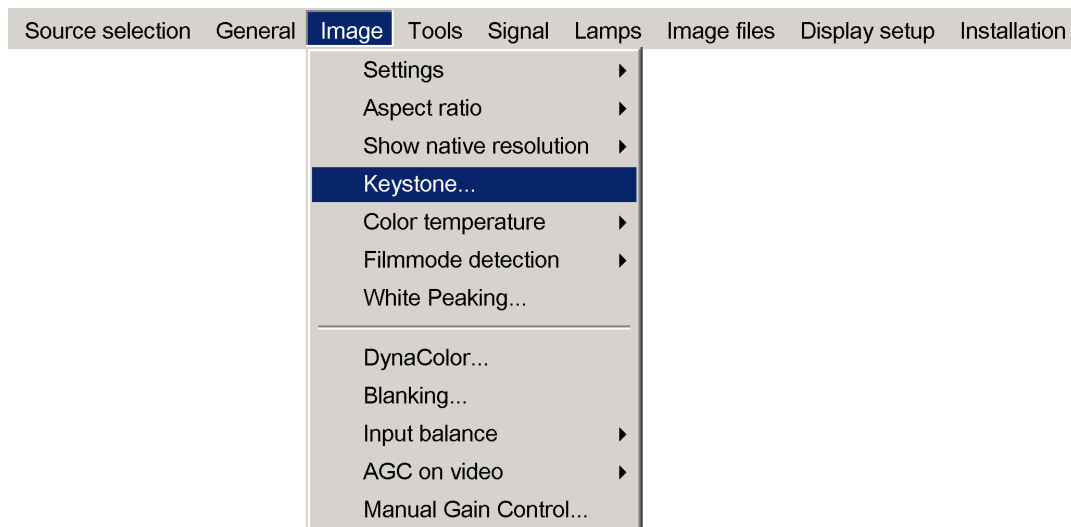

Image 6-29

5. Press **ENTER** to confirm

A sliderbox is displayed .

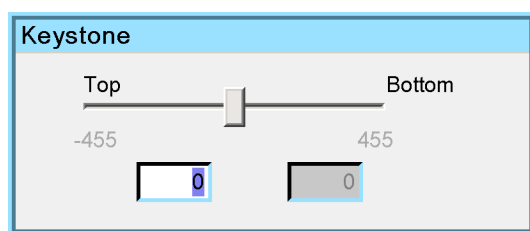

Image 6-30

Use **←** or **→**, the numeric keys on the remote, or the keypad to adjust the keystone.

The Top and bottom adjustments affect the image differently.

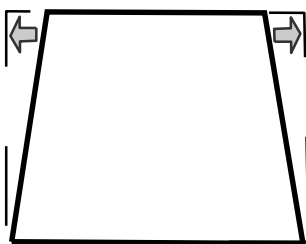

Image 6-31
Top adjustment of the keystone

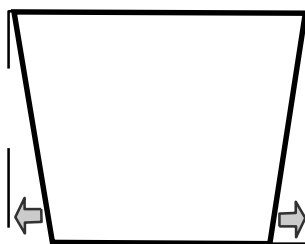

Image 6-32
Bottom adjustment of the keystone

6.4.5 Color temperature

What can be done ?

The color temperature can be selected according to the type of source:

There are 4 different preset color temperatures:

- Projector white
- computer : 9300 K
- Video : 6500 K
- Film : 5400 K
- Broadcast : 3200 K

These calibrated presets can be selected and will provide optimum color tracking, the projector allows however the setting of a personal color temperature, this is done in *custom*

How to select a preset color temperature ?

1. Press **MENU** to activate the Tool bar
2. Press → to select the *Image* item
3. Press ↓ to Pull down the *Image* menu
4. Use ↑ or ↓ to select *Color temperature*
5. Press → to pull down the menu
6. Use ↓ or ↑ to select the desired preset color temperature
7. Press **ENTER**

The color temperature of the image is adapted and a white bullet shows the active setting.

How to start up the custom color temperature ?

1. Press **MENU** to activate the Tool bar
2. Press → to select the *Image* item
3. Press ↓ to Pull down the *Image* menu
4. Use ↑ or ↓ to select *Color temperature*
5. Press → to pull down the menu
6. Use ↓ or ↑ to select *custom*
7. Press **ENTER**

A slider box for the red custom setting is displayed as well as a wizard text box in the lower part of the screen.

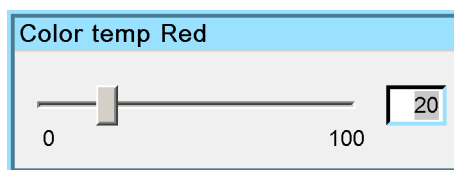

Image 6-33

Follow the instructions on the wizard textbox.



Image 6-34

6.4.6 Filmmode detection (video only)

What can be done ?

Some sources like common DVD material are derived from cinema 24 Hz sources (2/2 or 3/2 pull down method).

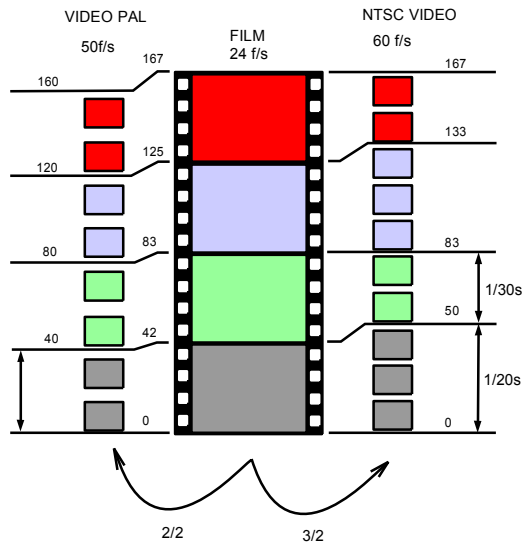

Image 6-35
film to video conversion: 2/2 and 2/3 pull down method

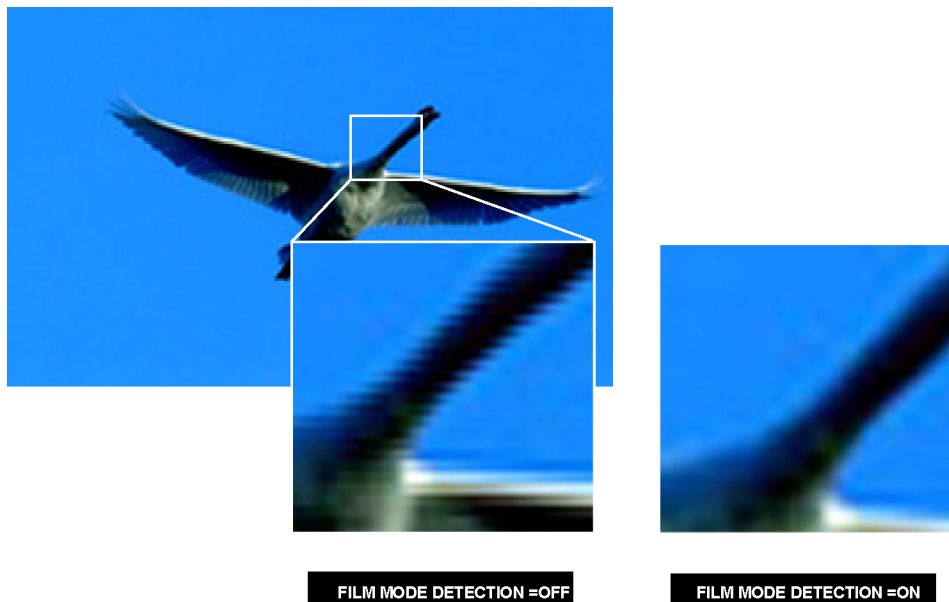

Image 6-36

The filmmode detection insures that these converted signals are shown without artefacts, especially motion artefacts due to bad de-interlacing.



This function may cause undesired effects on standard sources, therefore it can be disabled (OFF) at any time

Enabling/disabling the filmmode detection

1. Press **MENU** to activate the Tool bar
2. Press **→** to select the *Image* item
3. Press **↓** to Pull down the *Image* menu
4. Use **↑** or **↓** to select *Filmmode detection*
5. Press **→** to pull down the menu
6. Use **↓** or **↑** to enable or disable the Filmmode detection

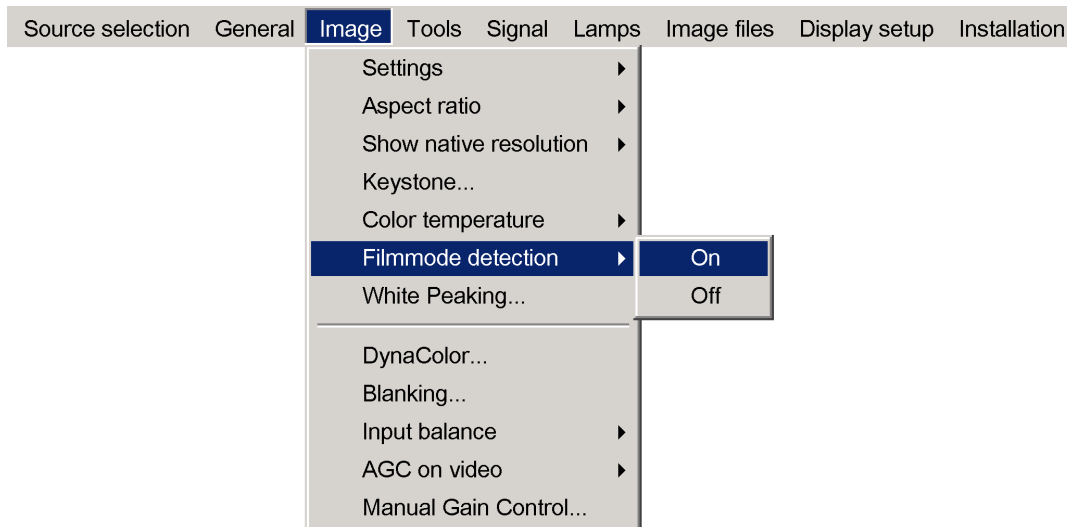

Image 6-37

7. Press **ENTER**

A white bullet shows the active setting

6.4.7 White peaking

White peaking

White peaking function will allow you to adjust the “white level” of the colors i.e. increasing the white peaking will increase the overall brightness of the image. Note that increasing the white peaking will decrease the color saturation.

How to adjust the White peaking level ?

1. Press **MENU** to activate the Tool bar
2. Press → to select the *Image* item
3. Press ↓ to Pull down the *Image* menu
4. Use ↑ or ↓ to select *White peaking*

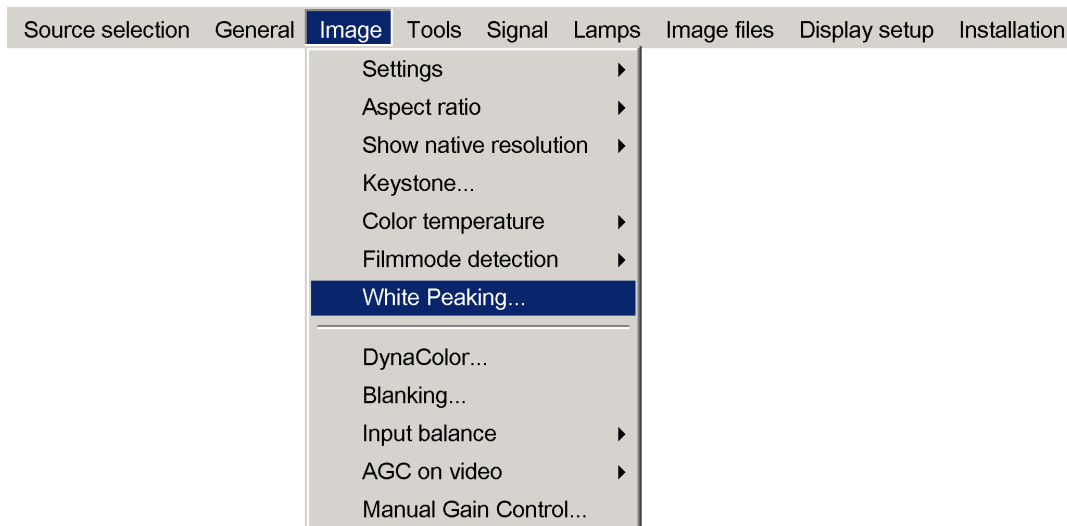

Image 6-38

5. Press **ENTER**

A slider box is displayed

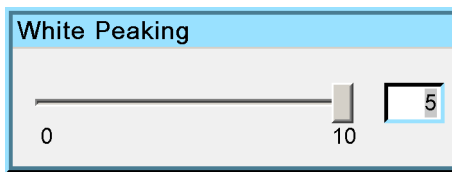

Image 6-39

6. Adjust the white peaking to the desired value

6.4.8 Dynacolor™

What can be done?

DynaColor™ will eliminate channel-to-channel color variations.

How to define color?

The CIE chromaticity diagram is one way to plot the colors the human eye can see.

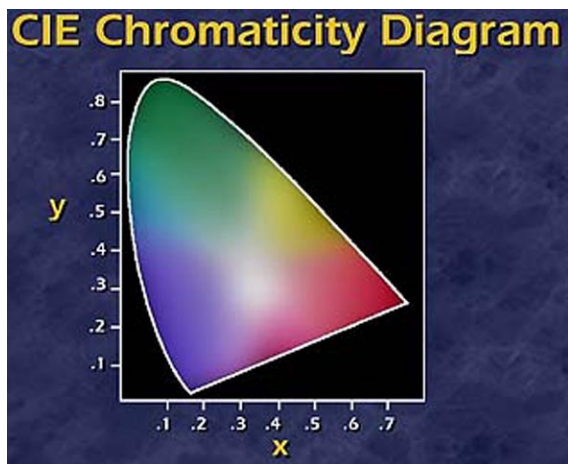

Image 6-40

The CIE chromaticity diagram

A projector can only reproduce a certain color gamut within this diagram. This color gamut is defined by the triangle formed by the x, y coordinates of Red Green and Blue. These parameters are used by the DynaColor™ adjustment.

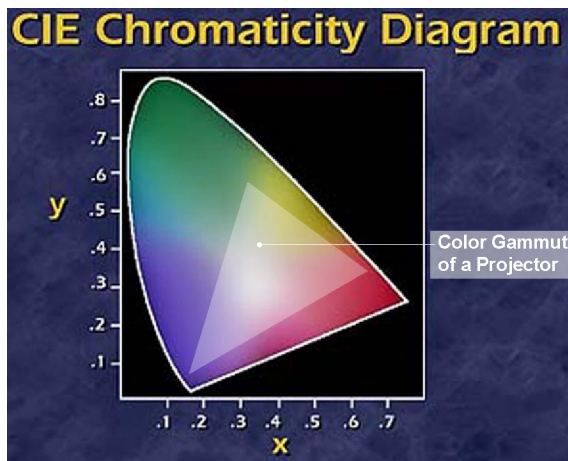

Image 6-41

The projector color gamut is defined by the triangle formed by the x, y coordinates of Red Green and Blue

Due to the tolerance on optical components the x, y values of this color gamut of each projector will differ.

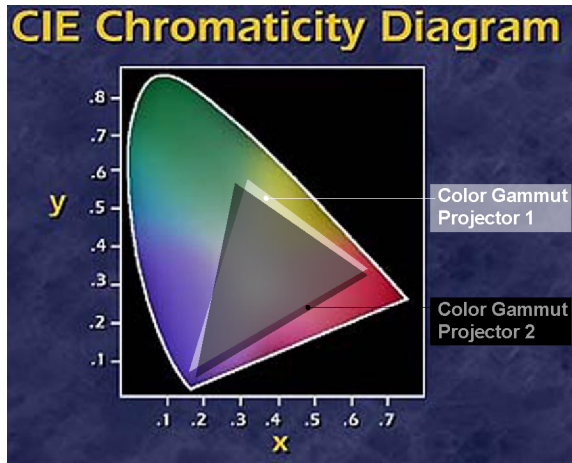

Image 6-42
The color gamut of each projector will differ

When working with a multichannel setup, these color differences between different projectors can be smoothed out by matching the color gamuts of the different projectors to a Common Color Gamut.

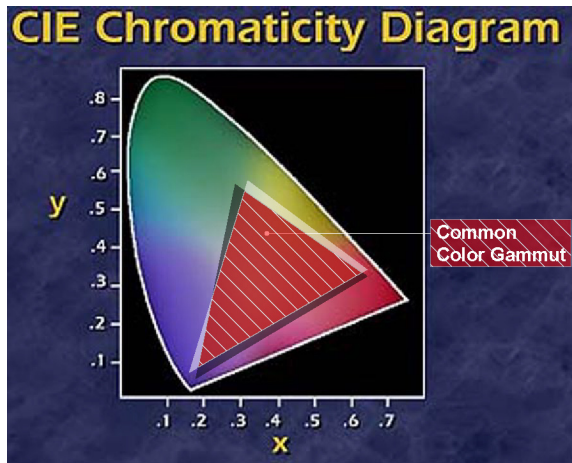

Image 6-43
Common Color Gamut

The Common Color Gamut

In a basic setup with 2 projectors, the perimeter of the Common Color Gamut is described by the 6 points of intersection of the 2 separate color gamuts.

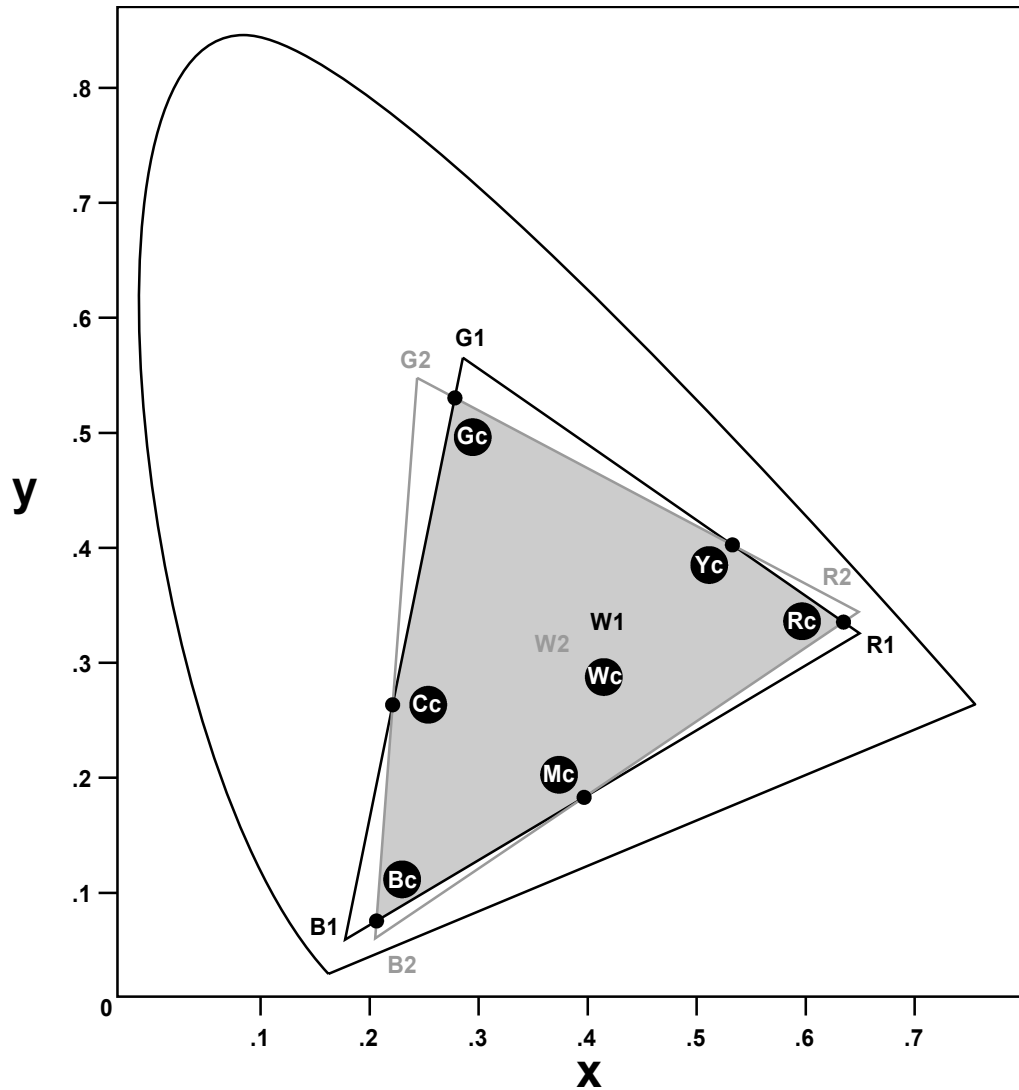

Image 6-44
The Common Color Gamut

R1 Red projector 1
 R2 Red projector 2
 G1 Green Projector 1
 G2 Green Projector 2
 B1 Blue Projector 1
 B2 Blue Projector 2
 W1 White Projector 1
 W2 White Projector 2
 Rc Red Common Color Gamut
 Gc Green Common Color Gamut
 Bc Blue Common Color Gamut
 Cc Cyan Common Color Gamut
 Mc Magenta Common Color Gamut
 Yc Yellow Common Color Gamut
 Wc White Common Color Gamut

The following parameters can be adjusted within DynaColor™:

- the x, y coordinates and g(Light Output) of the 6 Common Color Gamut perimeter points.
- the x, y coordinates and g(Light Output) of the White point of the Common Color Gamut.

How to Start up Dynacolor™?

1. Press the **MENU** key to activate the Menu bar.
2. Push the cursor key ← or → to highlight *Image* in the menubar.
3. Push the ↓ key to pull down the *Image* menu.
4. Push the cursor key ↑ or ↓ to highlight *Dynacolor* and press **ENTER** to select.

6. Advanced

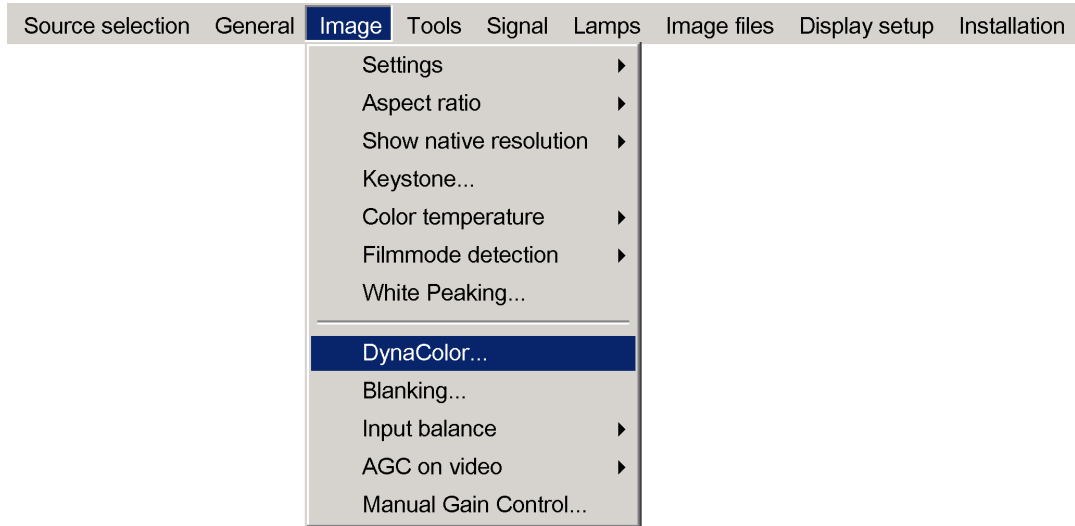

Image 6-45

The Dynacolor dialog box will be displayed.

Dynacolor

MEASURED

	x	y	L
Red	0.662	0.323	0.035
Green	0.341	0.550	0.364
Blue	0.144	0.101	0.055
White	0.286	0.345	0.455

DESIRED

	x	y	g
Red	0.662	0.323	0.035
Green	0.341	0.550	0.364
Blue	0.144	0.101	0.055
Cyan	0.252	0.347	0.420
Yellow	0.386	0.517	0.400
Magenta	0.231	0.139	0.091
White	0.299	0.340	1.000

Enabled
 Disabled

< ENTER > to edit/confirm
 or
 < EXIT > to return

Image 6-46

5. Push the cursor key ← or → select enable/diasable and then **ENTER**.

Dynacolor™ g (Light Output) Value

The value g in the Dyancolor™ interface represents a relative light output.

g=1 is the maximum available light output.



Assume we have a projector. L=1 in the Dynacolor™ interface will correspond with a 'maximum full white light' output of x Lumens.



Important ! In the projectors iD R600 and iD Pro R600 (R9010340 and R9010350) the measuring is done with white peaking = 0.

In the projectors iD R600+ and iD Pro R600+(R9010341 and R9010351) however, the white peaking must be 10 during the measurement.

The dialogbox shown here are as displayed in the iD R600 and iD Pro R600 (with the field White).The dialogbox displayed in the iD R600+ and iD Pro R600+ contain the field White+ instead of White.

The Dynacolor™ Interface

Following parameters are available in the Dyancolor™ Interface:

Measured Values	These are the colors the projector displays when no color changes are made
Red x, y	Coördinates for the Red point
Green x, y	Coördinates for the Green point
Blue x, y	Coördinates for the Blue point
White x, y	Coördinates for the White point
Red L	Red Light output
Green L	Green Light output
Blue L	Blue Light output
White L	White Light Output

Desired Values	These are the colors you want the projector to display when the status is enabled
Red x, y	Coördinates for the Red point
Green x, y	Coördinates for the Green point
Blue x, y	Coördinates for the Blue point
Cyan x, y	Coördinates for the Cyan point
Yellow x, y	Coördinates for the Yellow point
Magenta x, y	Coördinates for the Magenta point
White x, y	Coördinates for the White point
Red g	Red Light Gain
Green g	Green Light Gain
Blue g	Blue Light Gain
Cyan g	Cyan Light Gain
Yellow g	Yellow Light Gain
Magenta g	Magenta Light Gain
White g	White Light Gain

Status	Enables or disables Dynacolor™
Factory Preset	Sets the measured parameters back to the factory preset for the current set

Basic Dynacolor™ Adjustment

We assume we have a basic setup with 2 projectors, the Dynacolor™ adjustment is done by using only the Dynacolor™ menu:

1. Enable Dynacolor™ on both projectors.
2. Assume the first projector has the following measured values.

Dynacolor

MEASURED

	x	y	L
Red	0.662	0.323	0.035
Green	0.341	0.550	0.364
Blue	0.144	0.101	0.055
White	0.286	0.345	0.455

DESIRED

	x	y	g
Red	0.662	0.323	0.035
Green	0.341	0.550	0.364
Blue	0.144	0.101	0.055
Cyan	0.252	0.347	0.420
Yellow	0.386	0.517	0.400
Magenta	0.231	0.139	0.091
White	0.299	0.340	1.000

Enabled Disabled

< ENTER > to edit/confirm
or
< EXIT > to return

Factory Preset

Image 6-47

3. Assume the second projector has the following measured values.

Dynacolor

MEASURED

	x	y	L
Red	0.658	0.305	0.042
Green	0.327	0.546	0.337
Blue	0.139	0.100	0.045
White	0.290	0.353	0.423

DESIRED

	x	y	g
Red	0.658	0.330	0.042
Green	0.327	0.546	0.336
Blue	0.139	0.100	0.046
Cyan	0.246	0.356	0.381
Yellow	0.381	0.505	0.377
Magenta	0.251	0.148	0.086
White	0.304	0.351	1.000

Enabled Disabled

< ENTER > to edit/confirm
or
< EXIT > to return

Factory Preset

Image 6-48

4. We start by setting both projectors to the common red coordinate.

Tip: Draw a quick sketch of both gamuts as a graphical help.

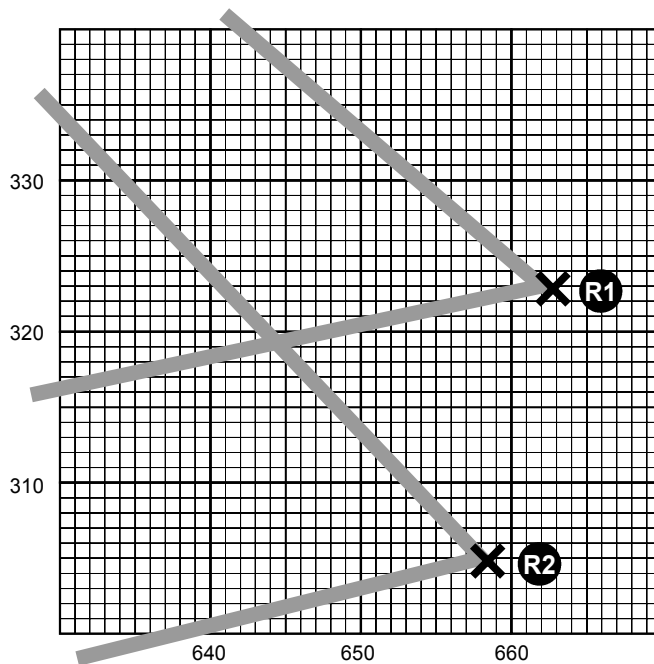

Image 6-49
Red coordinates for both projectors

5. Display the internal color bar pattern on both projectors.
6. In the desired values, adjust the red coordinate to a common value for both projectors.

Tip: The color bar of the adjusted coordinate will no longer be displayed in case the coordinate is not present within the gamut of the adjusted projector e.g. with the desired values for red set to $x=660$ and $y=318$.

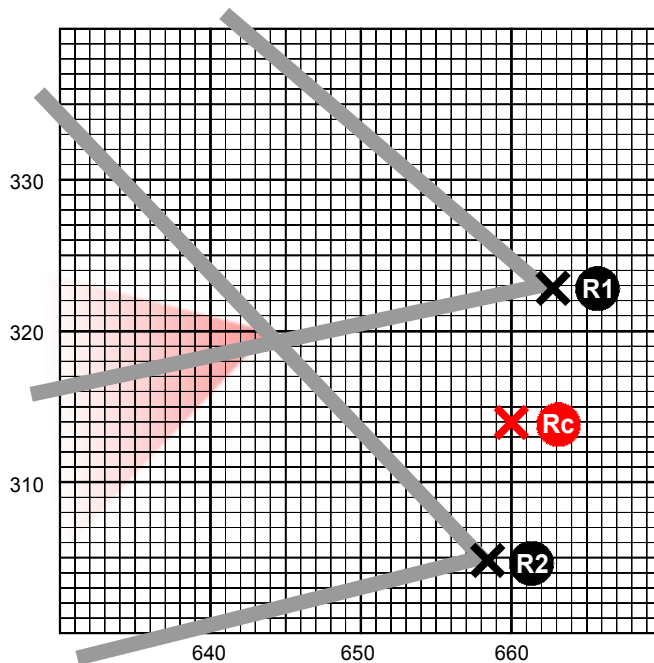

Image 6-50
Coordinate is not present within the gamut of the adjusted projector

6. Advanced

Select a coordinate that is present in the common gamut e.g. with the desired values for red set to $x=633$ and $y=328$.

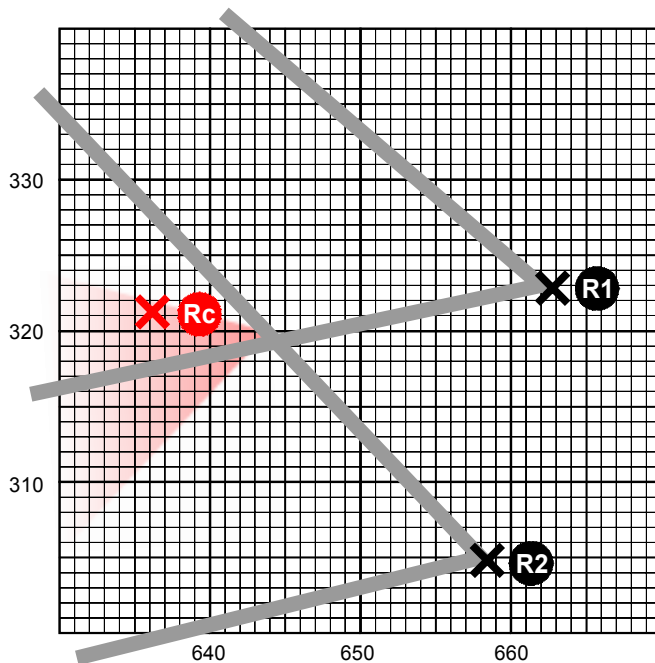

Image 6-51

Select a coordinate that is present in the common gamut

7. Repeat step 5 to 6 for all coordinates on both projectors.

Both projectors will now operate within the same color gamut.



Another way to determine the new coordinates is to use the DynacolorTool (software tool running on a laptop or PC), contact Barco for more information.

6.4.9 Blanking

Blanking in the Image menu

The blanking in general allows to blank unwanted video information (noise in the top or bottom of the image).

The blanking in the image menu is the same as in the Display settings menu except for the fact that here the blanking settings are stored in the image files. In other words each custom file or source has its own blanking values.

See the blanking procedure in the Display settings menu.



If the selected source is not entirely displayed always check first the blanking settings in the image menu since the active custom file may contains blanking.

6.4.10 Input balance

Introduction: Unbalanced color signals

When transporting signals, there is always a risk of deterioration of the information contained in the signals.

The alterations of the three color signals will happen independently i.e. the colors will end to be unbalanced,



Image 6-52

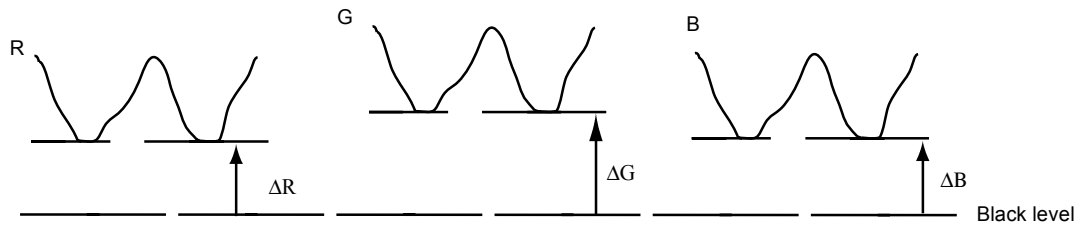

Image 6-53

The objective of input balancing

The objective in input balancing is to “set” the same black level and the same white level for the three colors of a particular input source.



Black level setting : brightness

White level setting : contrast

The same absolute black and white level for the three colors allows the same reference for Brightness and contrast control of the picture !

These two references also set the range in which the ADC will work for that particular source (this explains also why each input balance setting is linked to a particular source and thus saved in the image file).

How can it be done ?

To balance the three color signals of a particular source there are conditions; in fact we must know the black and the white level of the source i.e. :

1. the source in question must be able to generate a white signal, ideally a 100% white (background) full screen pattern
2. the source in question must be able to generate a black signal, ideally a 100 % black (background) full screen pattern

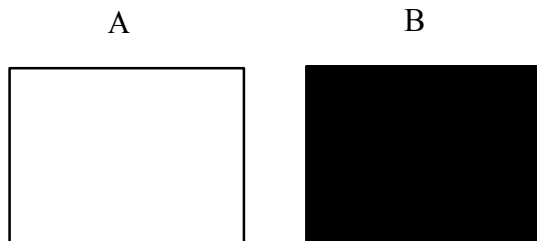

Image 6-54

White balance : In the projector, we will set the contrast for each color until we get a 100% light output picture when projecting a 100% white image (image A)

Black balance : In the projector, we will set the brightness for each color until we get a 0% light output picture when projecting a 100% black image (image B).



The changeover from min to max is indicated by the apparition of bright spots also called “digital noise”



An alternative to a full screen White/black pattern is the standard gray scale pattern, the white bar will be used for white balance and the black bar for black balance.

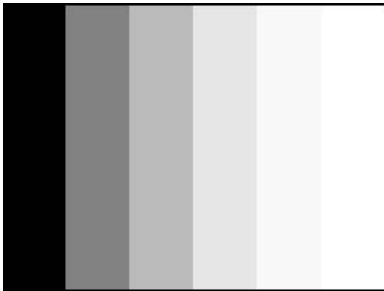

Image 6-55



It is not necessary to adjust the black balance. Its value is automatically set to an optimal value.

Performing White input balance

1. Select a black pattern (or gray scale as alternative)
2. Press **MENU** to activate the Toolbar
3. Press → to select the *Image* item
4. Press ↓ to Pull down the *Image* menu
5. Use ↑ or ↓ to select *Input balance*
6. Press → to pull down the menu
7. Use ↓ or ↑ to select *White balance*

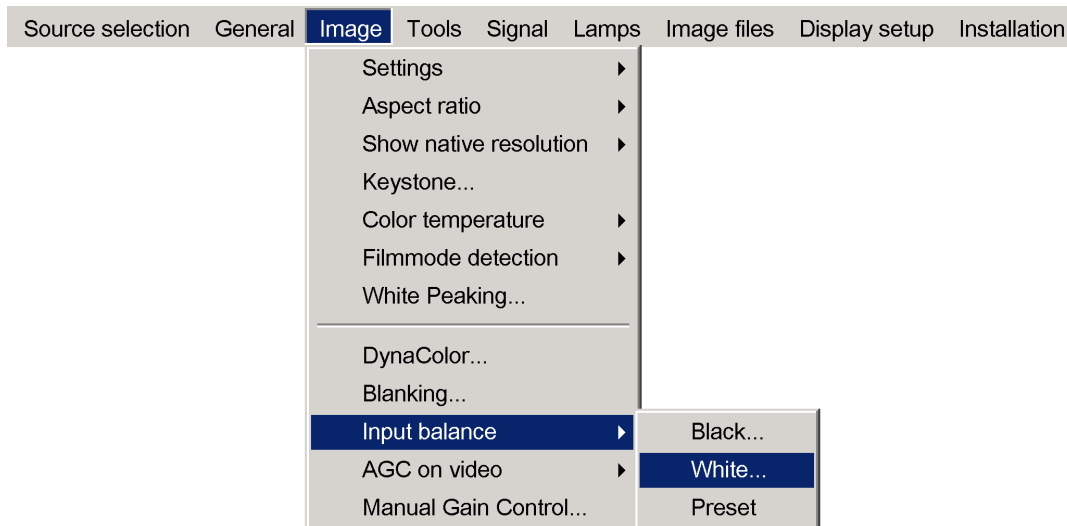

Image 6-56

8. Adjust the red white level (gain) on a minimal value

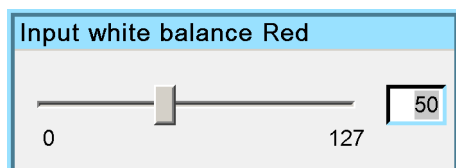

Image 6-57

9. Adjust the blue white level (gain) on a minimal value

Note: *this minimal value is not necessary , provided that the 2 other colors are not influencing too much the color to be adjusted, in fact the aim is to minimize the effect of the two other colors since there is a risk of reaching too soon the transition (bright spots) due to the contribution of these two other colors signals.*

10. Adjust the Green white level (gain) until bright spots appear on the white part of the image

11. Adjust the Blue white level (gain) until bright spots appear on the white part of the image

12. Adjust the Red white level (gain) until bright spots appear on the white part of the image

The projected image should now be noisy neutral grey.



if one uses a gray scale pattern, the bright spots should appear in the white bar.



Selecting *Preset* restores the factory input balance setting



The input balance settings are stored in the image file, each source has its own input balance.

6.4.11 AGC on Video



AGC

Automatic Gain Control: allows an automatic amplitude (gain) control of the incoming video signal



AGC is only for Video signals

Enabling/disabling the AGC

1. Press **MENU** to activate the Tool bar
2. Press → to select the *Image* item
3. Press ↓ to Pull down the *Image* menu
4. Use ↑ or ↓ to select *AGC on Video*
5. Press → to pull down the menu
6. Use ↓ or ↑ to enable or disable the AGC
7. Press **ENTER**

A white bullet shows the active setting

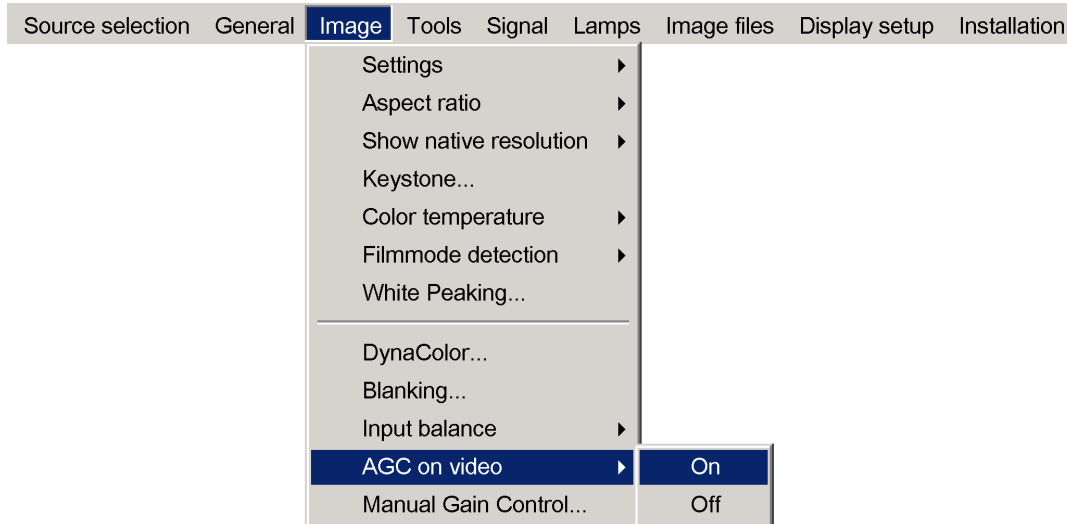

Image 6-58



The AGC can be disturbing in case of Macrovision encoded signals, therefore the AGC can be disabled (OFF) at any time

6.4.12 Manual Gain Control

What can be done ?

Beside the AGC there is the possibility to manually set the gain of the incoming video signal. When the AGC is enabled (ON), the manual setting does not affect the gain, AGC must therefore be disabled. The manual gain control must be done on an external pattern with white areas (grey scale bar pattern)

How to set the Manual Gain Control ?

1. Press **MENU** to activate the Tool bar
2. Press → to select the *Image* item
3. Press ↓ to Pull down the *Image* menu
4. Use ↑ or ↓ to select *Manual Gain Control*

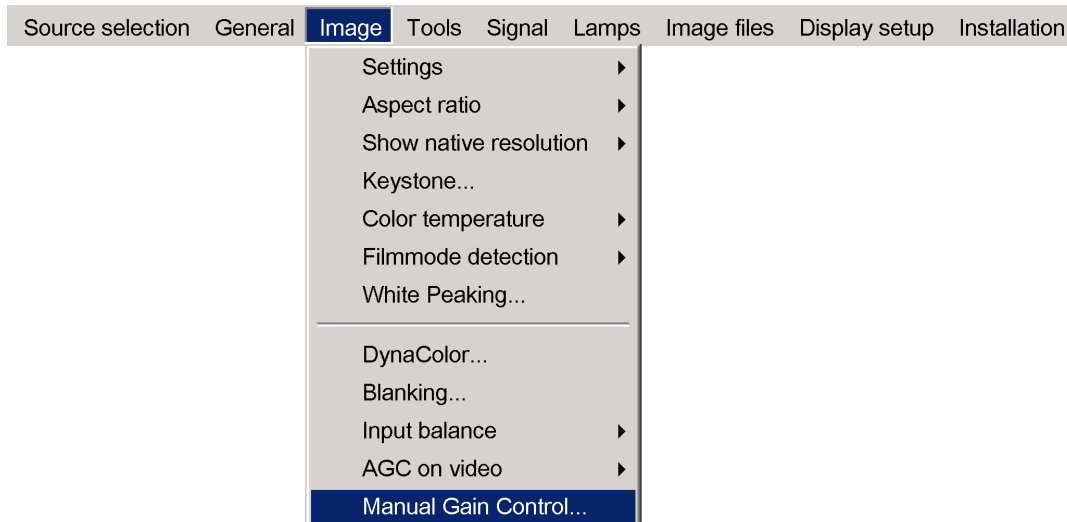

Image 6-59

5. Press **ENTER**

A scroll bar is displayed

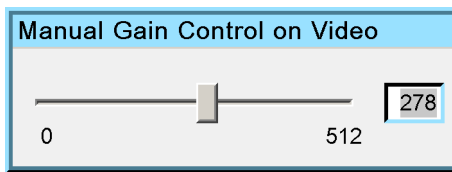

Image 6-60

6. Use ← or →, the numeric keys on the remote, or the keypad to change the gain so as to obtain homogeneous white parts in the image.

6.5 Tools

6.5.1 Introduction to PiP



PIP

PiP stands for "Picture in Picture" and allows to display multiple windows containing each of them an image. The windows may be of the video or data type.

What are the different possibilities within the PiP mode ?

The input section of the IQ projector allows a multitude of combinations of different input signals which may be projected in the 4 windows of the PiP screen.

The PiP mode allows independent settings for each window:

- Image settings : contrast, brightness, tint, color,...
- Vertical and horizontal shift of each window all over the screen
- Resizing of the window
- Digital Zoom
- Linking of (an) audio input(s) to a single or multiple windows

What are the different PiP layouts ?

- Full screen²

The full screen is used to display one of the selected sources. Browsing through the sources is possible with the **PiP Adjust** button on the remote.

- 2-by-2 raster²

The screen is divided into 4 subscreens containing 2 Video and 2 Data sources.

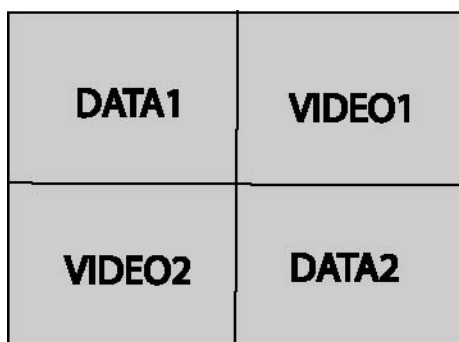

Image 6-61
PiP: 2by2 layout

- PiP layout 1–3 ³

These are factory layouts, they can be edited and saved.

- Personal layouts

Beside the 2 fixed layouts and the 3 factory layouts, one can set 5 additional (personal) layouts.

PiP dedicated buttons

- **PiP Adjust** : this button allows to focus on one particular window, this is shown with a white frame surrounding the selected window.
A source identification box is displayed in the right lower corner.

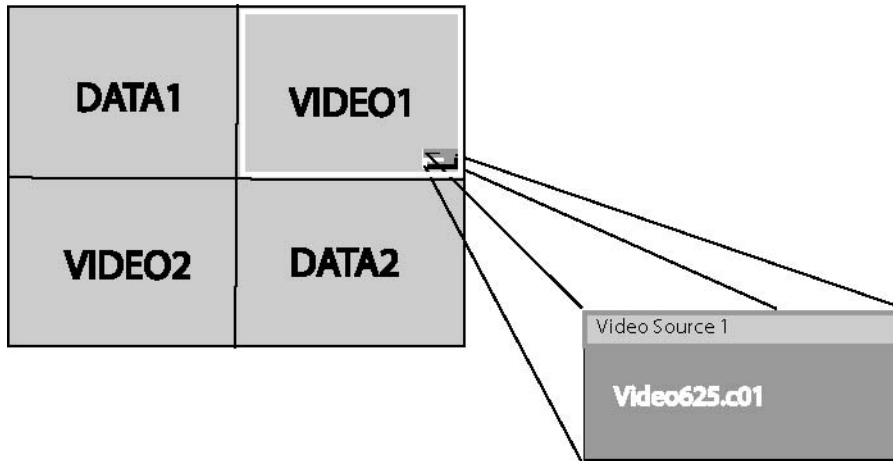

Image 6-62

Pressing the button removes the frame to the next window. This can also be done via *PiP Adjust* in the Tools menu

- **PiP**: this button allows to browse through the different configurations, it has the same function as *PiP select* in the Tools menu.



Since there is only one decoder (second decoder is optional), when in 2by2 configuration, Video1 and Video2 are derived from the same video source.

6.5.2 PiP select

PiP layouts

The different PiP layouts (configurations) can be selected in the PiP select menu.

How to change the PiP configuration ?

1. Press **MENU** to activate the Tool bar
2. Press → to select the *Tools* item
3. Press ↓ to Pull down the *Tools* menu
4. Use ↑ or ↓ to select *PiP select*
5. Press → to pull down the menu
6. Use ↑ or ↓ to select the desired configuration
7. Press **ENTER**

A white bullet shows the active layout

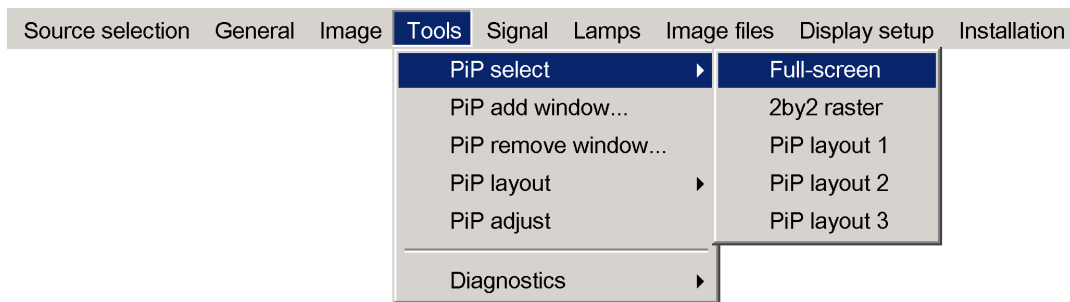

Image 6-63



The PiP configuration can also be selected via the dedicated PiP key on the RCU.

6.5.3 PiP add window

What can be done ?

It is possible to add a window to the existing windows (maximum 4), therefore a source must be selected.

Sources which are already used are non selectable. If, for instance, the PiP layout contains a component video then component video will be non selectable.

Once added, the window may be altered in several ways to meet particular needs:

- repositioning
- re-sizing
- changing the order

How to add a window ?

1. Press **MENU** to activate the Tool bar
2. Press → to select the *Tools* item
3. Press ↓ to Pull down the *Tools* menu
4. Use ↑ or ↓ to select *PiP add window*
5. Press **ENTER**

The source selection menu is displayed

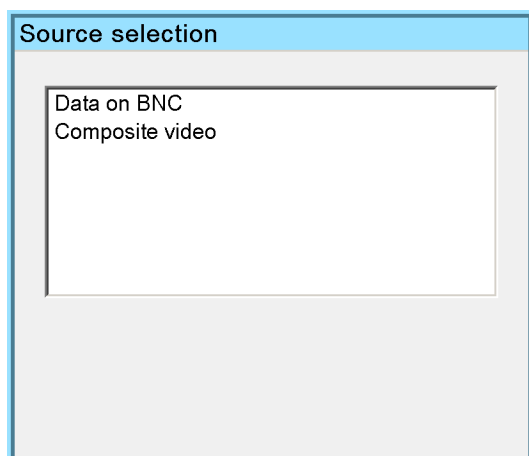

Image 6-64

In the lower part of the screen appears a wizard in 4 steps

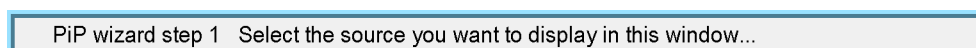



Image 6-65

6.5.4 PiP remove window

How to remove a window ?

1. Press **MENU** to activate the Tool bar
2. Press → to select the *Tools* item
3. Press ↓ to Pull down the *Tools* menu
4. Use ↑ or ↓ to select *PiP remove window*
5. Press **ENTER**

In the lower part of the screen appears a wizard.



Change color between Red and Blue with <-COLOR+ >

Image 6-66

The selected window appears surrounded with a white frame, each hit on **PiP ADJUST** will move the frame along the different windows.

6.5.5 PiP layout

Overview

- PiP Save
- PiP rename layout
- PiP delete layout

6.5.5.1 PiP Save

What can be done ?

The active layout can be saved or "saved as".

When a new layout is saved it is added to the *PiP select* menu.



A fixed layout can be edited (re-sizing, re-positioning,...) but it can not be saved under its original name.

How to save a layout ?

1. Press **MENU** to activate the Tool bar
2. Press → to select the *Tools* item
3. Press ↓ to Pull down the *Tools* menu
4. Use ↑ or ↓ to select *PiP layout*
5. Press → to pull down the menu
6. Use ↑ or ↓ to select *PiP save* or *save as*
7. Press **ENTER**

If *save as* has been selected, a dialog box is displayed

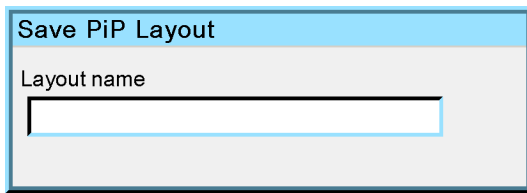

Image 6-67

Use ← or →, the numeric keys on the remote, or the keypad to enter the name and exit with **BACK** or **MENU**.

If *save as* has been selected, a message box is displayed

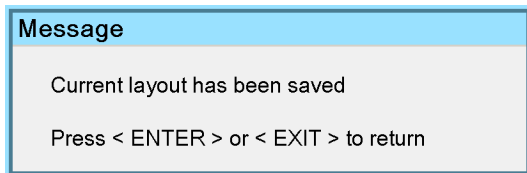

Image 6-68

6.5.5.2 PiP rename layout

What can be done ?

The non fixed layouts (factory and personal layouts) can be renamed .

The maximal length of the name is 12 characters.



A fixed layout can not be renamed

How to rename a layout ?

1. Press **MENU** to activate the Tool bar
2. Press → to select the *Tools* item
3. Press ↓ to Pull down the *Tools* menu
4. Use ↑ or ↓ to select *PiP layout*
5. Press → to pull down the menu
6. Use ↑ or ↓ to select *Rename*
7. Press **ENTER**

A dialog box is displayed

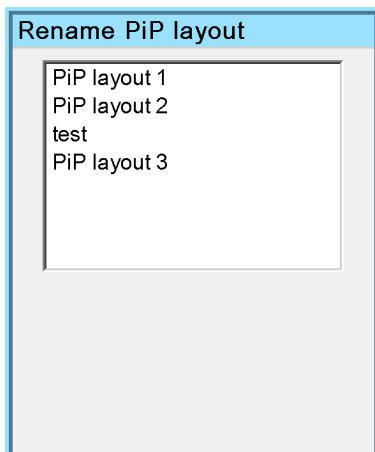

Image 6-69

8. Use ↑ or ↓ to select the layout to be renamed

9. Press **ENTER**

A dialog box is displayed

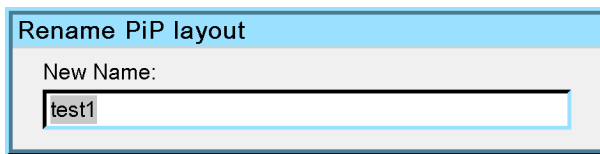

Image 6-70

Use ← or →, the numeric keys on the remote, or the keypad to enter the name and exit with **BACK** or **MENU**.

6.5.5.3 PiP delete layout

What can be done ?

The non fixed layouts (factory and personal layouts) can be deleted.



The fixed layouts and the active layout can not be deleted

How to delete a layout ?

1. Press **MENU** to activate the Tool bar
2. Press → to select the *Tools* item
3. Press ↓ to Pull down the *Tools* menu
4. Use ↑ or ↓ to select *PiP layout*
5. Press → to pull down the menu
6. Use ↑ or ↓ to select *Delete*
7. Press **ENTER**

A dialog box is displayed

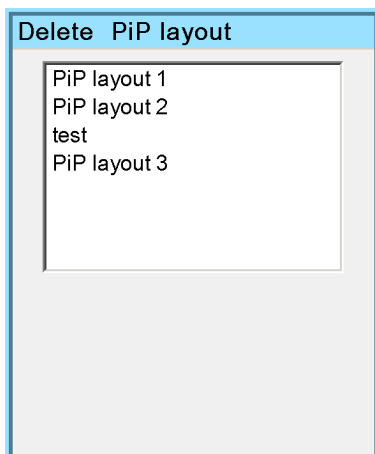

Image 6-71

8. Use ↑ or ↓ to select the layout to be renamed
9. Press **ENTER**

The layout is deleted and disappears from the dialog box

6.5.6 PiP Adjust

What can be done ?

PiP adjust allows to browse through the windows in the active layout, a white frame indicates the window which has the focus.

This way, independent settings (picture settings, ...) are possible for each window.



This can also be done by using the dedicated PiP Adjust key on the RCU

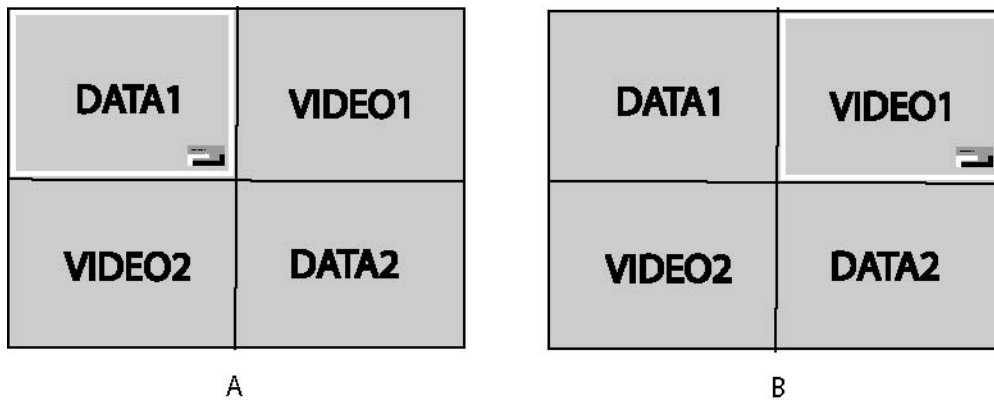

Image 6-72
PiP adjust in case of 2by2 layout

- A Data1 window has the focus, new settings will only affect Data1 window
 B Video1 window has the focus, new settings will only affect Video1 window

PiP adjust

1. Press **MENU** to activate the Toolbar
 2. Press **→** to select the *Tools* item
 3. Press **↓** to Pull down the *Tools* menu
 4. Use **↑** or **↓** to select *PiP Adjust*
 5. Press **ENTER**
The menu disappears.
- The focus moves to the next window when pressing **ENTER** (clockwise rotation)
- If you press **BACK** or if you wait 5 seconds the menu is displayed.



When using the PiP adjust key on the RCU the corresponding source box is displayed in the bottom right corner.

How to adjust a window in the layout ?

1. Use the PiP Adjust key or function in the menu to choose the window to be adjusted
2. Press **ENTER**
A wizard bar is displayed in the bottom of the screen
Follow the procedure.

6.5.7 Color keying

Principle of color keying

Take e.g. two image. One taken on a full color background and the other a normal image. The full color background will be replaced by the second image via the principle of color keying.



Image 6-73
Zebra on a single color



Image 6-74
Full color image



Image 6-75
Result image after color keying



The color keying function is only relevant when in presence of the Pro version, although present in the standard version.

6.5.8 Diagnostics

Diagnostics

1. See the Troubleshoot section in the appendix

6.6 Signal Menu

Overview

- Switching mode
- Background

6.6.1 Switching mode

Switching from one source to another

To minimize undesired effects when switching from one source to another, one can use the Seamless switching mode, beside Seamless switching there is a wide choice of several effects which render the source switching transitions more enjoyable.

How to select a switching mode ?

1. Press **MENU** to activate the Tool bar
2. Press **→** to select the *Signal* item
3. Press **↓** to Pull down the *Signal* menu
4. Use **↑** or **↓** to select *Switching mode*
5. Press **→** to pull down the menu
6. Use **↑** or **↓** to select the desired switching mode

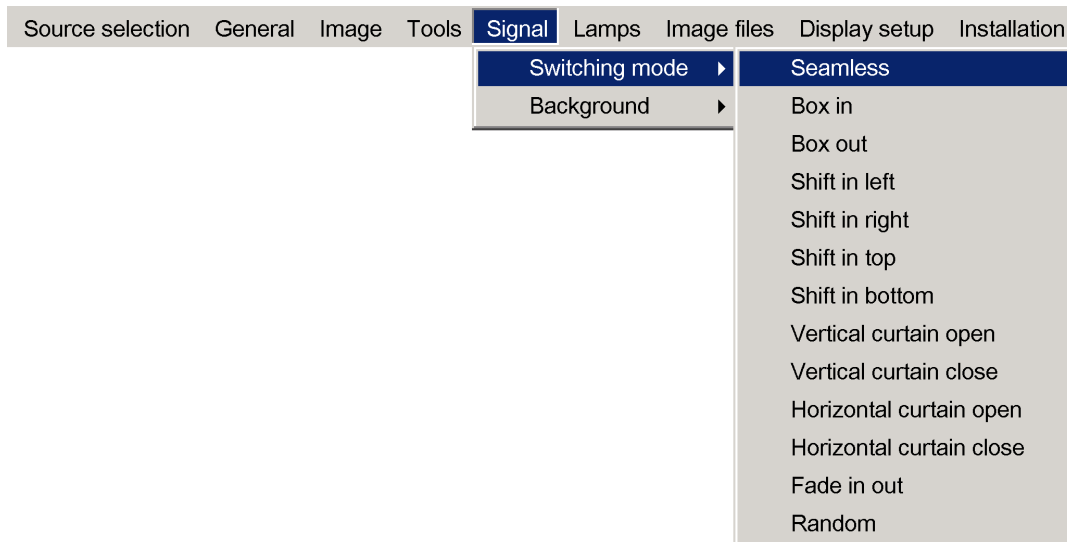

Image 6-76

7. Press **ENTER**

A white bullet shows the active effect.

The next source switching will be done using the selected effect



The *Random* mode will select a new switching mode at each source switching i.e. there will never be 2 successive source switchings with the same effect.

The *Seamless* switching mode is not used in the *Random* mode.



The switching effects are only possible in the full screen mode



When the source switching mode is the fade in/out mode, the audio (when available) switching will also be done using a fade in/out effect.

6.6.2 Background

Purpose

If there is no signal connected to the projector, the background will be a logo, a black or a blue screen depending on the *background* settings.

How to change the background ?

1. Press **MENU** to activate the Toolbar
2. Press → to select the *Signal* item
3. Press ↓ to Pull down the *Signal* menu
4. Use ↑ or ↓ to select *Background*
5. Press → to pull down the menu
6. Use ↑ or ↓ to select the desired background

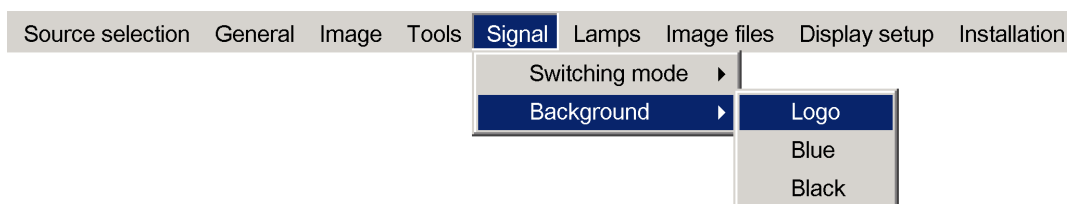

Image 6-77

7. Press **ENTER**



The logo display is only possible in the full screen mode, a logo can thus not be displayed (rescaled) in a window in the PIP mode.



When there is no signal connected, the projector will also start its standby timer countdown (if enabled) and shuts down after the predetermined time.

6.7 Lamp management

6.7.1 Runtimes

How to display the lamp runtimes ?

1. Press **MENU** to activate the Toolbar
2. Press **→** to select the *Lamp* item
3. Press **↓** to Pull down the *Lamp* menu
4. Use **↑** or **↓** to select *Runtimes*

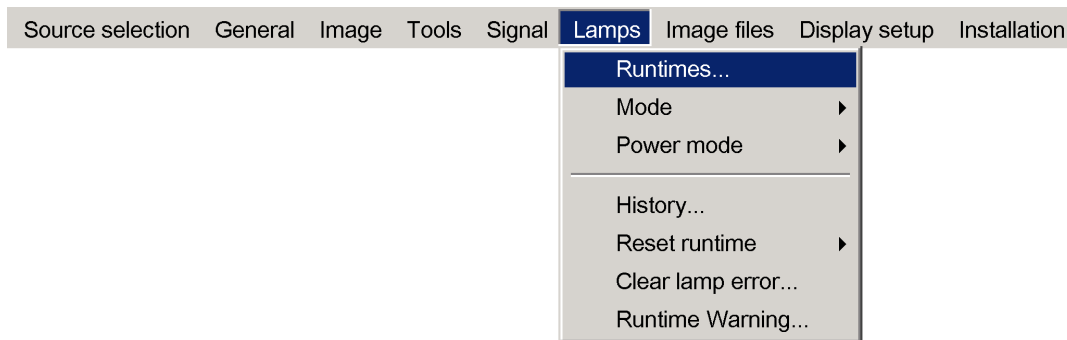

Image 6-78

5. Press **ENTER**

A textbox is displayed

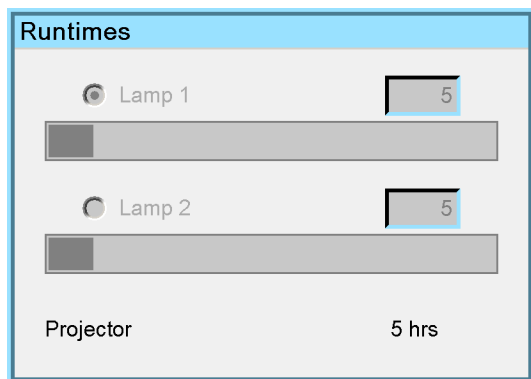

Image 6-79

6.7.2 Mode

What are the different lamp modes ?

Single mode

The projector will always switch to the lamp with the shortest runtime when the difference between the runtimes of lamp1 and lamp 2 reaches **100 hours**, switching from one lamp to another happens only at switching on of the projector and not during operation.

When the lamp fails or reaches its maximum runtime the projector switches automatically to the other lamp without interrupting the projection. The failure is logged and the lamp will never be initialized in the future.

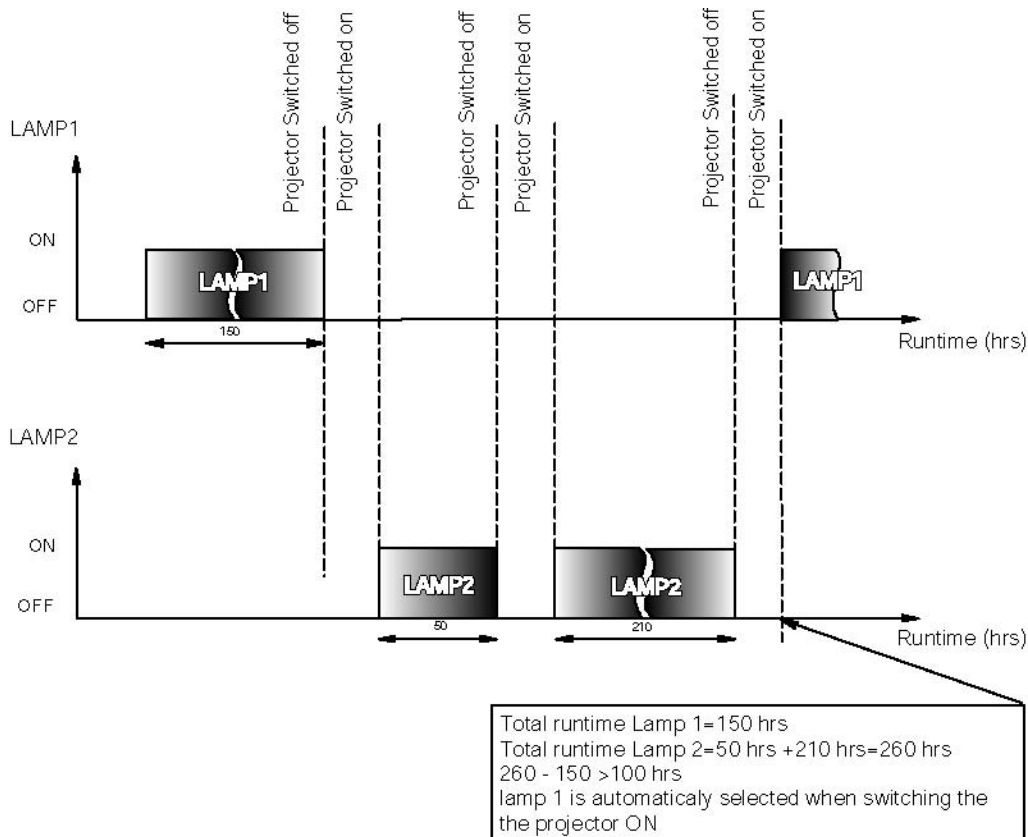

Image 6-80
Single mode operation: switching principle

Dual mode

Both lamps are working.

When one lamp fails, the projector continues the projection using the remaining lamp.

How to select the lamp mode ?

1. Press **MENU** to activate the Toolbar
2. Press **→** to select the *Lamp* item
3. Press **↓** to Pull down the *Lamp* menu
4. Use **↑** or **↓** to select *Mode*
5. Press **→** to pull down the menu
6. Use **↑** or **↓** to select the desired background

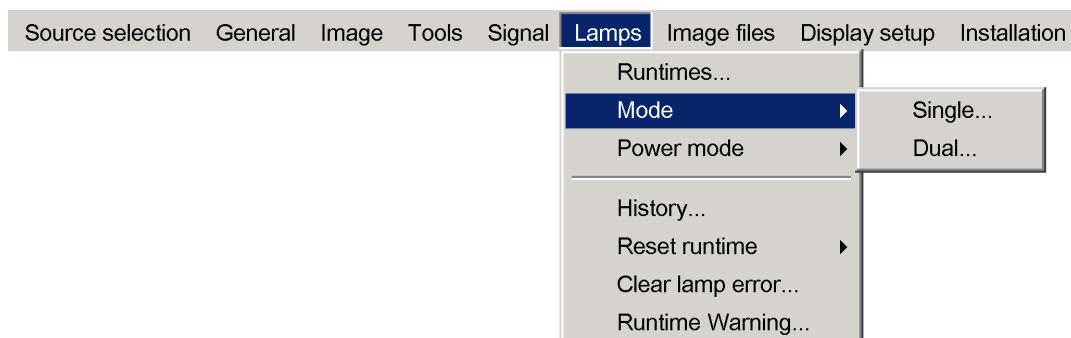

Image 6-81

7. Press **ENTER**

A bullet shows the active mode.



When switching from the dual mode to the single mode the lamp with the longest runtime is switched off.
If the runtimes are equal (if the projector has always been operated in dual mode) then lamp1 is switched out.



When switching to single mode, returning to the dual mode will not be possible in the first 60 seconds, *Dual* in the menu is greyed out and LED1 is flickering, thereby preventing hot restrike which may damage the lamp.

6.7.3 History

How to view the history ?

1. Press **MENU** to activate the Tool bar
2. Press **→** to select the *Lamp* item
3. Press **↓** to Pull down the *Lamp* menu
4. Use **↑** or **↓** to select *History*

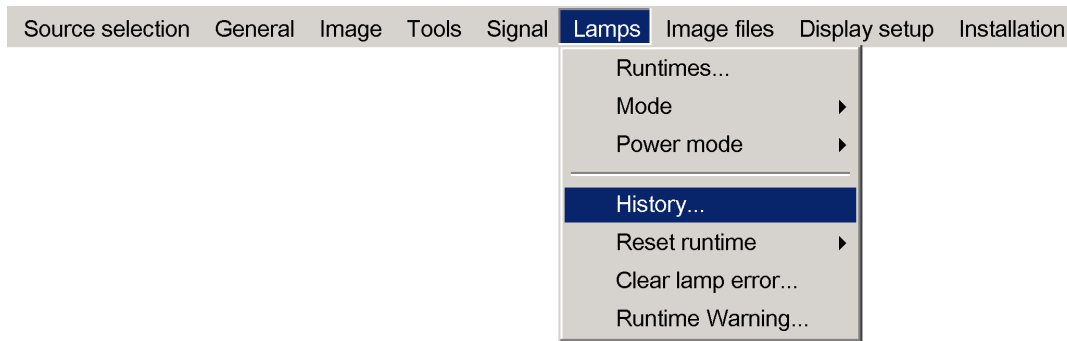

Image 6-82

5. Press **ENTER**

A textbox is displayed

Lamp history		
Lamp	Serial no.	Runtime
L1	0001230	900
L2	0001222	900
Current lamps		
L1	0001240	900
L2	0001242	900

Image 6-83

6.7.4 Runtime warning

What can be done ?

When the lamp has reached a certain predetermined runtime , a warning message will be displayed on the screen. The lamp runtime warning can be set in a range from 30 to 200 hours. The runtime warning is displayed by default at 30 hours before end of lamp lifetime.

How to set the lamp runtime warning?

1. Press **MENU** to activate the Toolbar

2. Press → to select the *Lamp* item
3. Press ↓ to Pull down the *Lamp* menu
4. Use ↑ or ↓ to select *Runtime warning*

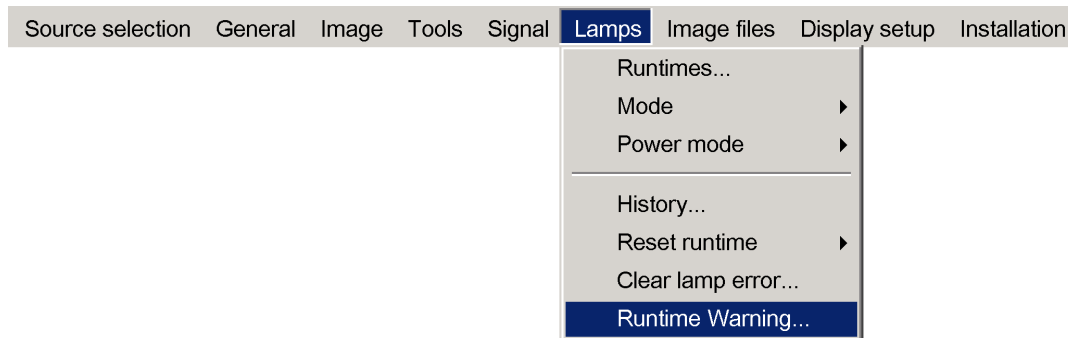

Image 6-84

5. Press **ENTER**

A dialogbox is displayed

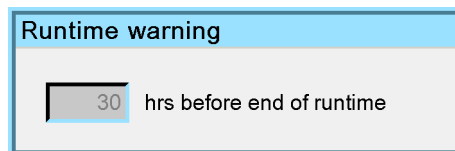

Image 6-85

6. Use ← or →, the numeric keys on the remote, or the keypad to change the runtime warning setting.



WARNING: Lamp runtime reset as well as the lamp replacement can only be done by a Barco authorized technician.

6.8 Image files menu

Overview

- Load file
- Auto Image
- Edit file
- Rename file
- Copy
- Delete
- Forced file load

6.8.1 Load file

How to load a file ?

1. Press **MENU** to activate the Tool bar
2. Press → to select the *Image files* item
3. Press ↓ to Pull down the *Image files* menu
4. Use ↑ or ↓ to select *Load*

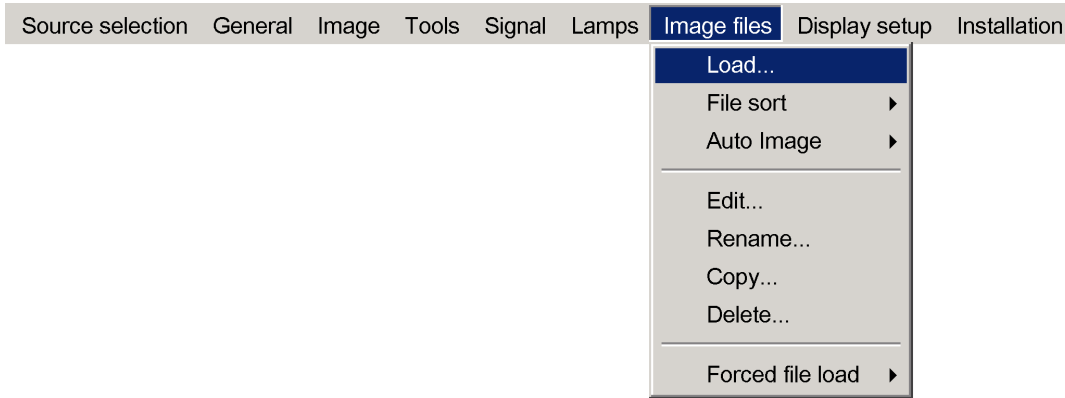

Image 6-86

5. Press **ENTER**
A dialog box is displayed

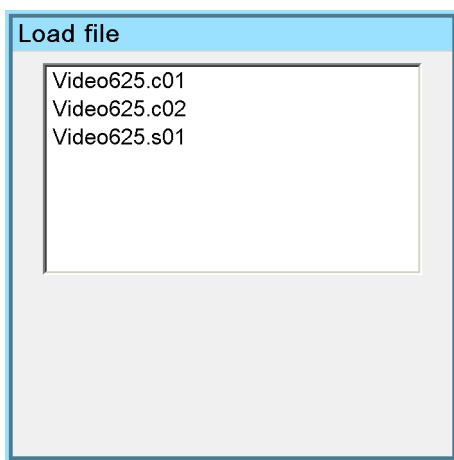

Image 6-87

6. Use ↑ or ↓ to select the desired file
Tip: For more info about the available image files and the specifications see the Image files section.
7. Press **ENTER**
The file is loaded and the image is adapted.



In PiP mode, the files which may be loaded will be of the data type if the active window is a data window, or they will be of the video type if the active window is a video window.

What to do if the image is not perfect ?

If the displayed image is not correct after AutoImage or after selecting the best fitting file, go to the Edit menu, select the active file and change the settings.

6.8.2 Auto Image

What can be done ?

Auto Image creates the best suited image file for the connected source.

It calculates/measures several source parameters :

- Total pixels per line
- Start pixel
- Phase
- Contrast/Brightness levels



Auto Image works only for data images.

The measure of the total number of pixels per line can be done through 2 methods

- Limited scan: a windowing is used to allow fast tracking.
The operation takes about 20 seconds (depending on file)
- Full scan: tracking is done over the full range.
The operation takes about 1.5 minutes (depending on file)

How to launch Auto Image?

1. Press **MENU** to activate the Tool bar
2. Press → to select the *Image files* item
3. Press ↓ to Pull down the *Image files* menu
4. Use ↑ or ↓ to select *Auto Image*
5. Press → to open the menu
6. Use ↑ or ↓ to select the desired file scan method

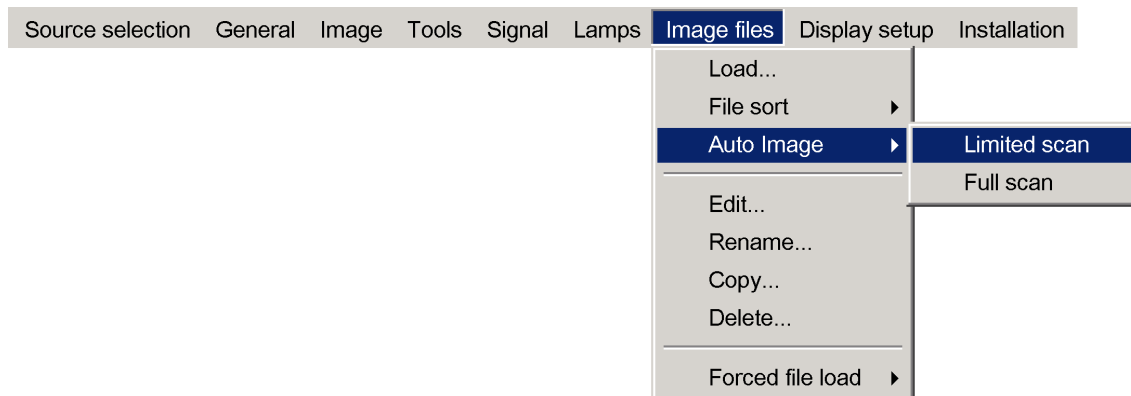

Image 6-88

7. Press **ENTER**
A text box showing a progress bar is displayed.

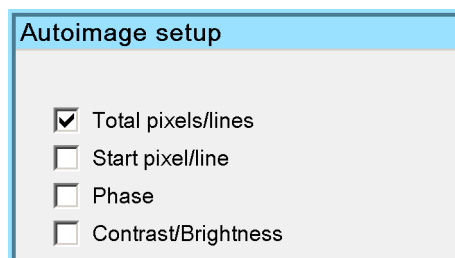

Image 6-89

Tip: Press the **Cancel** button to cancel the operation.



The Auto Image setup in the *Display setup* menu affect only Auto Image if it is launched via the RCU key or at automatic file creation.

Launching Autolmage via the menu involves complete checking of all parameters.



Auto Image can also be launched via the RCU with the dedicated Autolmage key.

6.8.3 Edit file

What can be done with the Edit file menu ?

The Edit file menu makes it possible to change the settings of the file according to the real settings of the connected source. Consult the source specifications before entering the data.

How to edit a file ?

1. Press **MENU** to activate the Tool bar

6. Advanced

2. Press → to select the *Image files* item
3. Press ↓ to Pull down the *Image files* menu
4. Use ↑ or ↓ to select *Edit*

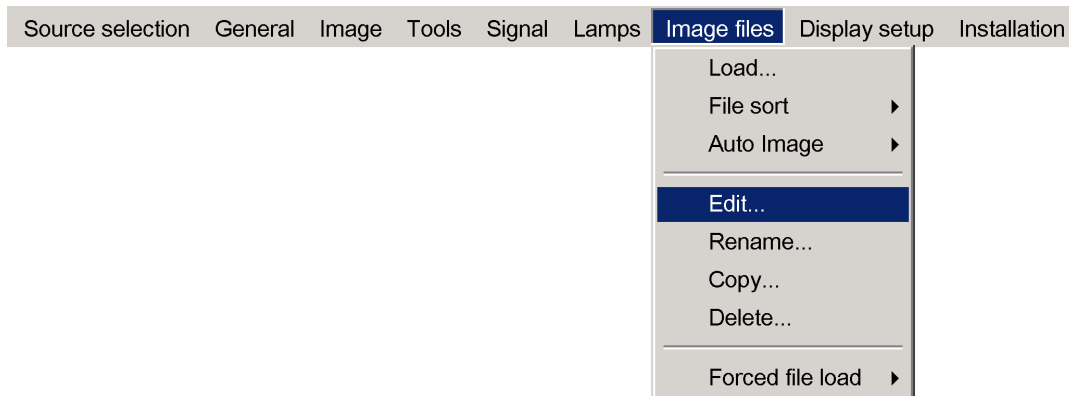

Image 6-90

5. Press **ENTER**
A dialog box is displayed
6. Use ↑ or ↓ to select the desired file
Note: *If in PiP mode the cursor is placed by default on the active file which has the focus.*
7. Press **ENTER**
A dialog box is displayed

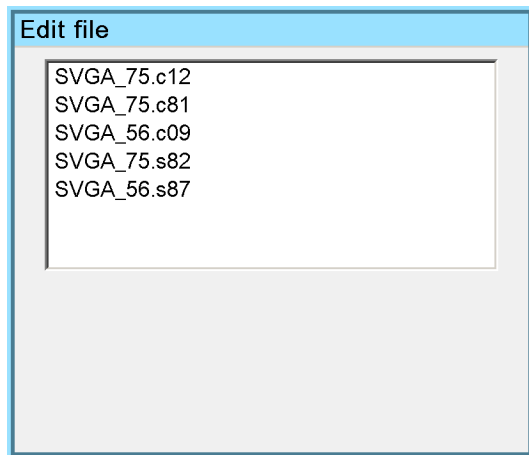

Image 6-91

8. Press **ENTER**

A dialog box is displayed

Edit file

Name SVGA@75.c12

Horizontal:

Total: pixels

Active: pixels

Start: pixels

Period: pixels

Vertical:

Total: lines

Active: lines

Start: lines

Image 6-92

9. Use ← or →, the numeric keys on the remote, or the keypad to edit and change the values, confirm with ENTER

Note: greyed out fields can not be updated (total pixels)

Which items can be adjusted ?

The following items can be adjusted :

- Active horizontal pixels
- Horizontal start in pixels
- Horizontal period in ns
- Active vertical lines
- Vertical start in lines

Advanced video settings

Advanced

Comb filter

ON

OFF

AGC hold interval

Short

Long

Sync locking

Slow

Fast

Sharpness

Coarse

Fine

Image 6-93

The **advanced** button enables the advanced settings for a video source.

6. Advanced

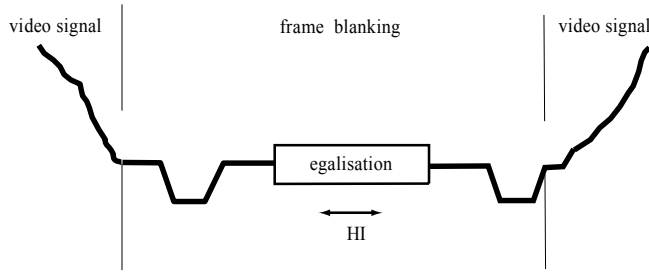

Image 6-94
HI AGC Hold interval

The **Comb filter** is by default enabled.

The **AGC hold interval** is the time interval in which the AGC is inhibited (AGC hold = no update in video amplitude measurement), the advanced parameter allows to choose a short or long hold interval.

A long AGC hold interval eliminates Macrovision® disturbances since the AGC is hold during a long interval, thus reducing the probability to encounter a Macrovision® pulse.

The **sync locking setting** is recommended for poor video signals (ex: poor TV signals).

Sharpness adjustment can be chosen to be coarse or fine.



It is recommended to use the default values.

Advanced Data settings

The **advanced** button enables the advanced settings for a data source.

Advanced edit

VCO Range

PLL Cmpm

Clamp position

Clamp width

Stereo Sync
 Yes
 No

Input format
 RGB
 PrYPb
 HDTV-PrYPb

Image 6-95

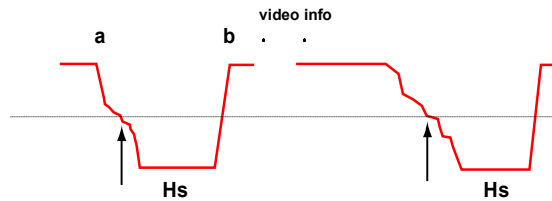

Image 6-96
Hs horizontal sync pulse
a active low
b active high

The **VCO range** setting determines the frequency range of the VCO (Voltage Controlled Oscillator).

The **Cmpm** (Charge pump current) sets the low pass filter current.

Both VCO range & Cmpm are set by the image file, changing these settings is only indicated in for special purposes.

The **horizontal sync polarity** setting can be useful in case of a bad shaped edge, one can choose between the leading (active low) or trailing (active high) edge.

The input format settings are used to "tell more" about the signals connected on the BNC's, it completes the information in the source selection menu.

- RGB is selected by default and means that an RGB signal is connected to the BNC's
- PR/Y/PB must be selected whenever:

- a progressive signal (32 kHz frequency video signal) is connected to the BNC's (select the source with *Data on BNC's* in the Source selection menu).
- one wants (in PIP mode) to visualize the component video signal in a Data window hereby adding a video image in the PiP layout.

-HDTV-PR/Y/PB for high definition component video signals.



It is recommended to use the default values.

6.8.4 Rename file

How to rename a file ?

1. Press **MENU** to activate the Tool bar
2. Press **→** to select the *Image files* item
3. Press **↓** to Pull down the *Image files* menu
4. Use **↑** or **↓** to select *Rename*

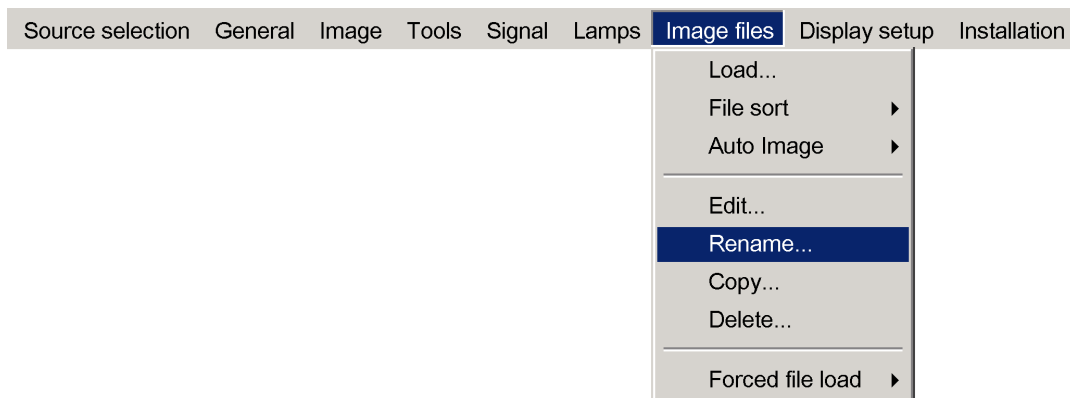

Image 6-97

5. Press **ENTER**
A dialog box is displayed

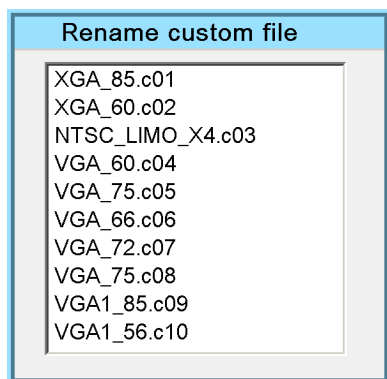

Image 6-98

6. Use **↑** or **↓** to select the desired file
7. Press **ENTER**

A text box is displayed

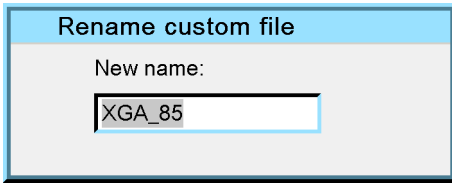

Image 6-99

Use ← or →, ↓ or ↑ the numeric keys on the remote, or the keypad to edit and change the values, confirm with ENTER.

6.8.5 Copy

How to copy a file ?

1. Press **MENU** to activate the Tool bar
2. Press → to select the *Image files* item
3. Press ↓ to Pull down the *Image files* menu
4. Use ↑ or ↓ to select *copy*

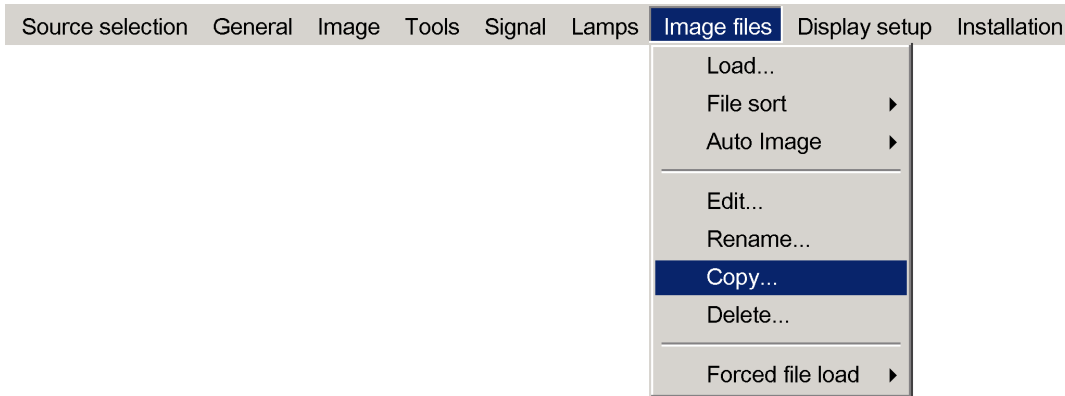

Image 6-100

5. Press **ENTER**
A dialogbox is displayed

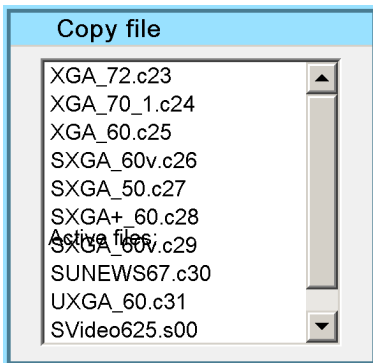

Image 6-101

6. Use ↑ or ↓ to select the desired file
7. Press **ENTER**

A text box is displayed

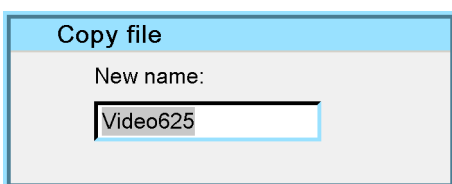

Image 6-102

Use ← or →, ↓ or ↑ on the remote, or the keypad to enter the new name, confirm with **ENTER**.



If the AutoImage function does not succeed in finding a file and no file is loaded (load list is empty), which means that the source is not displayed, then use the *copy* function: Copy a standard file (.std) which is not too different of the source to display, then edit this file to get the best image.

6.8.6 Delete

How to delete a file ?

1. Press **MENU** to activate the Tool bar
2. Press → to select the *Image files* item
3. Press ↓ to Pull down the *Image files* menu
4. Use ↑ or ↓ to select *delete*

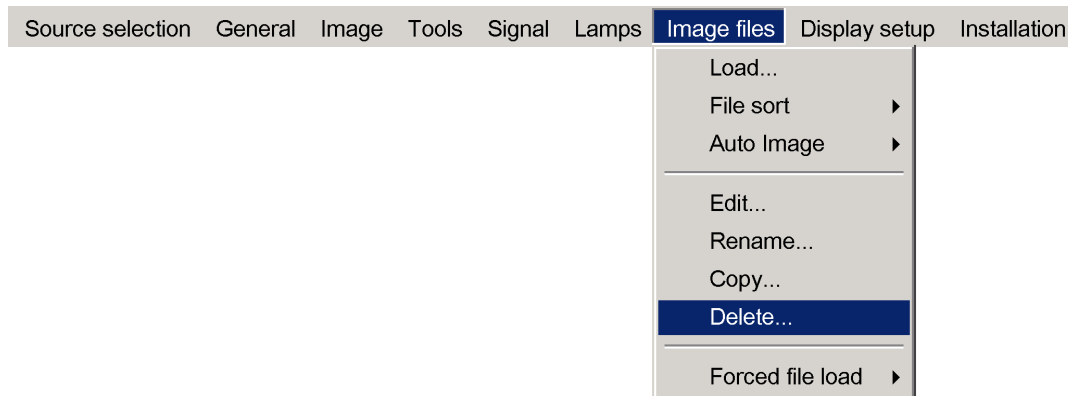

Image 6-103

5. Press **ENTER**
A dialog box is displayed

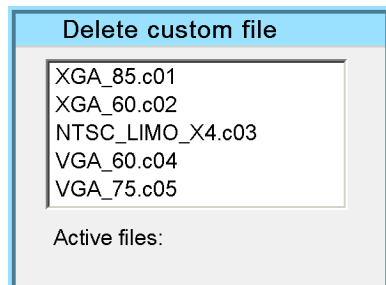

Image 6-104

6. Use ↑ or ↓ to select the desired file
7. Press **ENTER**
The selected file is deleted and is removed from the list

6.8.7 Forced file load

What can be done ?

Forced file load allows to force or lock one particular custom file to be loaded for one particular input. This way one can guarantee that the same desired file is always used for a particular source.

For each layer (layer 1, layer 2, layer 3) we can enable or disable the forced file load. The specification for the file to be selected for each input on that layer is done via RS232.



see the **RS232 User Guide** for more information on the **Forced file load** command to be sent.

How to set a file to be loaded ?

1. Press **MENU** to activate the Tool bar

6. Advanced

2. Press → to select the *Image files* item
3. Press ↓ to Pull down the *Image files* menu
4. Use ↑ or ↓ to select *Forced file load*
5. Press → to open the menu

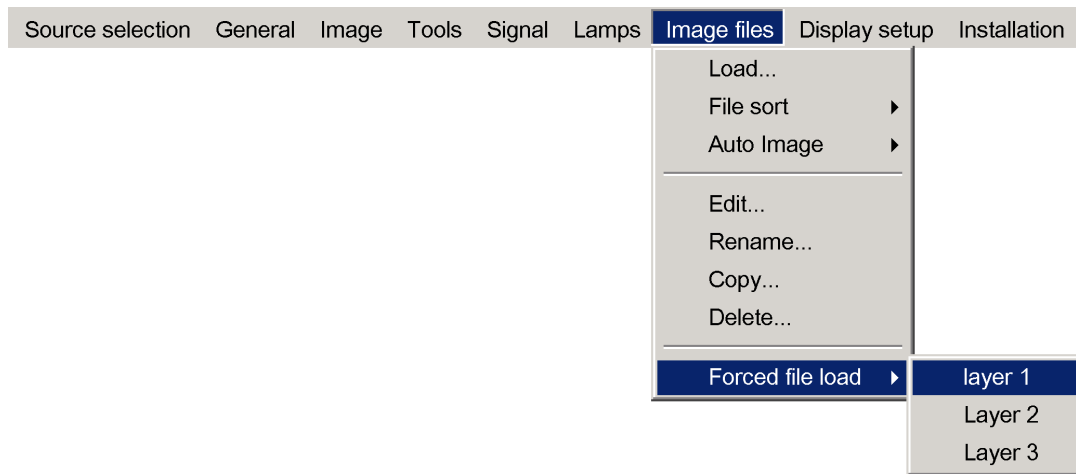

Image 6-105

6. Use ↑ or ↓ to select the desired layer
7. Press **ENTER**
Forced file load is activated for this layer (this is shown with a bullet)

6.9 Display Setup

Overview

- Full screen representation
- Startup screen
- Textbox
- Take screenshot
- Menu bar position
- Status bar position
- Sliderbox position
- AutoImage Setup
- Blanking
- Soft Edge

6.9.1 Full screen representation

Purpose of the Full screen representation

The *Full screen representation* function forces to use the complete native resolution of the LCD panels independently of the native resolution of the source.

Note that the full screen representation does not preserve the aspect ratio of the source, i.e. when the aspect ratio of the active image is not the same as the projector (in this case 1920/1080 or 1.77:1), the image will end to be distorted (stretched or shrunk).

How to enable/disable the full screen representation ?

1. Press **MENU** to activate the Tool bar
2. Press → to select the *Display setup* item
3. Press ↓ to Pull down the Display setup menu
4. Use ↑ or ↓ to select *Full screen representation*
5. Press → to pull down the menu
6. Use ↓ or ↑ to select ON or OFF

7. Press **ENTER**



The full screen representation will not guarantee the best image quality, therefore the *Show native resolution* has to be selected.

The *show native resolution* function on the other hand forces to use the native resolution of the source.

The *Full screen representation* function overrules the *show native resolution* function.



The aspect ratio setting is greyed out when enabling the full screen representation.

6.9.2 Startup screen

What can be done ?

When the startup screen is enabled, the identification screen is displayed for a few seconds at startup. This startup screen can also be disabled.

Identification	
Type	iDR500
Address	2
Software	01.02
RS232 baudrate	115200
Serial number	6001758

Image 6-106

How to enable/disable the Startup screen?

1. Press **MENU** to activate the Tool bar
2. Press → to select the *Display setup* item
3. Press ↓ to Pull down the *Display setup* menu
4. Use ↑ or ↓ to select *Startup screen*
5. Press → to pull down the menu
6. Use ↓ or ↑ to select the ON or OFF
7. Press **ENTER**

6.9.3 Textbox

What can be done ?

The textbox function allows to display or not the different sliderboxes used for instance for picture settings (contrast,...), it also affects the source information windows (displayed in the right lower corner of the screen).

How to enable/disable the Textbox ?

1. Press **MENU** to activate the Toolbar
2. Press → to select the *Display setup* item
3. Press ↓ to Pull down the *Display setup* menu
4. Use ↑ or ↓ to select *Textbox*
5. Press → to pull down the menu
6. Use ↓ or ↑ to enable/disable the textbox
7. Press **ENTER**

6.9.4 Take screenshot

What can be done ?

A screenshot can be taken from an active projected image. This screenshot is then saved in a 4 MB RAM and can be used as background.

Each new screenshot erases the previous logo therefore a warning message is displayed asking the user to confirm.

How to take a screenshot ?

1. Press **MENU** to activate the Tool bar
2. Press → to select the *Display setup* item
3. Press ↓ to Pull down the *Display setup* menu
4. Use ↑ or ↓ to select *Take screenshot*
5. Press **ENTER**

A dialog box is displayed. Press **yes** to confirm.

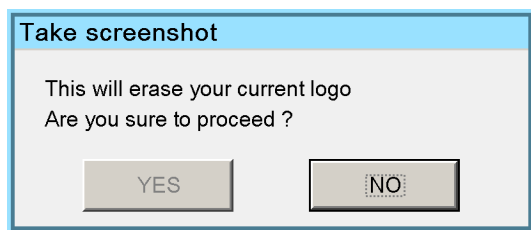

Image 6-107

A text box shows the evolution of the operation.

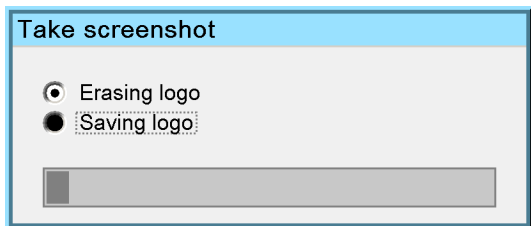

Image 6-108

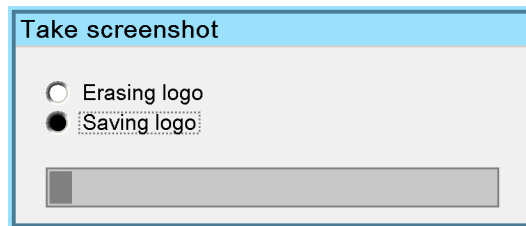

Image 6-109

6.9.5 Menu bar position

What can be done ?

The menu toolbar can be centered vertically , the range being from top of the screen to the middle of the screen. This can be useful in applications where the top image content is not displayed.

How to center the menu ?

1. Press **MENU** to activate the Toolbar
2. Press → to select the *Display setup* item
3. Press ↓ to Pull down the *Display setup* menu
4. Use ↑ or ↓ to select *Menu bar position menu*
5. Press **ENTER**
6. Use ↑ or ↓ to position the menu toolbar

6.9.6 Status bar position

What can be done ?

The status bar (wizard menu) can be centered vertically , the range being from bottom of the screen to the middle of the screen. This can be useful in applications where the bottom image content is not displayed.

How to center the menu ?

1. Press **MENU** to activate the Toolbar

2. Press → to select the *Display setup* item
3. Press ↓ to Pull down the *Display setup* menu
4. Use ↑ or ↓ to select *Status bar position*
5. Press **ENTER**
6. Use ↑ or ↓ to position the status bar

6.9.7 Sliderbox position

What can be done ?

The sliderbox can be displayed anywhere on the screen, the position can be set in this menu.

How to reposition the sliderbox?

1. Press **MENU** to activate the Tool bar
2. Press → to select the *Display setup* item
3. Press ↓ to Pull down the *Display setup* menu
4. Use ↑ or ↓ to select *Sliderbox position*
5. Press **ENTER**

A sliderbox is displayed. Use the 4 arrow keys to drag the box to the desired position.

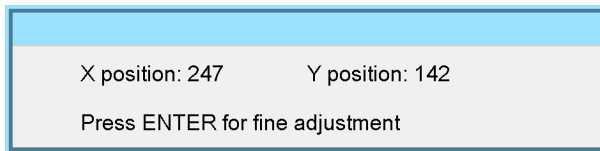

Image 6-110



There is a coarse and a fine adjustment of the position, use ENTER (when sliderbox is displayed) to switch between the two.

6.9.8 AutoImage Setup

What can be done ?

Autoimage allows to detect automatically the characteristics of the source (total pixels per line,...) and uses this information to adapt the image to the LCD panels.

Autoimage can adapt the image based on following data :

- Total pixels per line
- Start pixel
- Phase
- Contrast/brightness levels



Autoimage works only for data signals.

How to set up AutoImage?

1. Press **MENU** to activate the Tool bar
2. Press → to select the *Display setup* item
3. Press ↓ to Pull down the *Display setup* menu
4. Use ↑ or ↓ to select *Autoimage setup*
5. Press **ENTER**

6. Advanced

A dialog box is displayed.

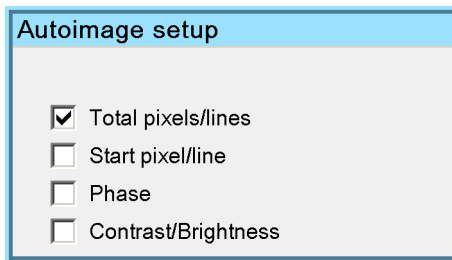

Image 6-111

6. Use the arrow keys to select the desired item and press **ENTER** to activate or deactivate the item.

How to perform AutoImage ?

1. Press **AutoImage** on the RCU

A textbox showing a progress bar is displayed.



During the **AUTOIMAGE** measuring process the data source disappears temporarily (logo is displayed if background is set to logo)

6.9.9 Blanking

What can be done ?

The image can be blanked in several ways :

- Top blanking
- Bottom blanking
- Left blanking
- Right blanking



100

Bmax

Left blanking

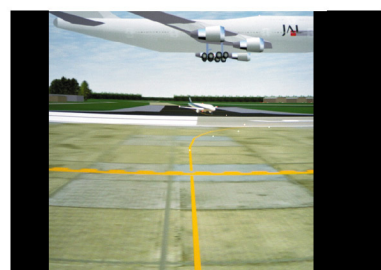

Bmax

Right blanking

Image 6-112



Note that here the blanking is only done on the display i.e. the setting is not saved in the image file. in other words only one type of blanking (setting) can be done independently of the source.

How to blank the image ?

1. Press **MENU** to activate the Toolbar
2. Press **→** to select the *Display setup* item
3. Press **↓** to Pull down the menu
4. Use **↑** or **↓** to select *Blanking*
5. Press **ENTER**

A slider box is displayed

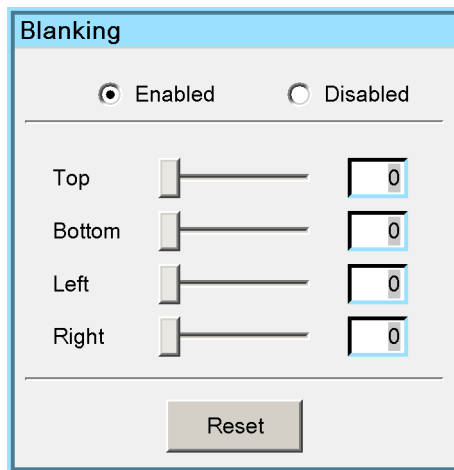

Image 6-113

6. Use **←** or **→**, the numeric keys on the remote, or the keypad to change the blanking.



Use the checkboxes to enable/disable the blanking
Use the Reset key to reset the blanking values.



The logo is also affected by the blanking

6.9.10 Soft Edge

Overview

- Introduction
- Soft Edge overlap zone (horizontal Soft Edge)
- Soft Edge border adjustment
- Black level of the images

6.9.10.1 Introduction

Why Soft Edge?

When working in a multichannel setup the projector and its Soft Edge possibilities allow an image blending that gives the appearance of a single view.

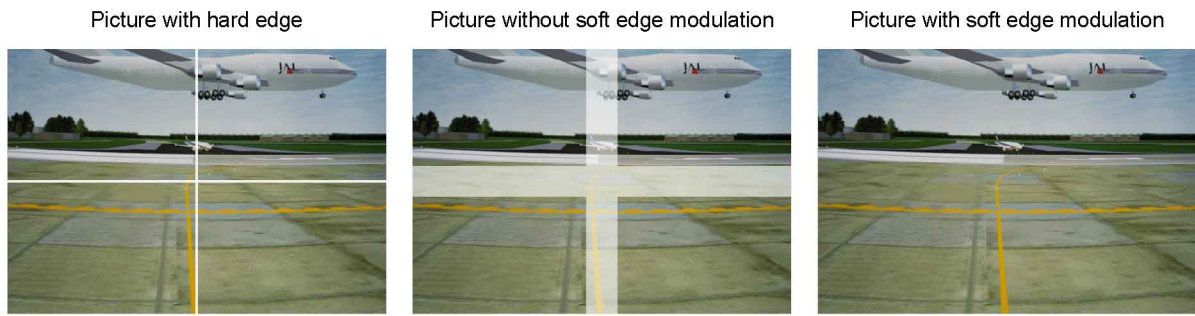

Image 6-114
Why Soft Edge?

What is the Basic Principal of Soft Edge?

The principle of edge blending is achieved by linear modulation of the light output in the overlap zone so that the light output in that zone equals the light output of the rest of the image.

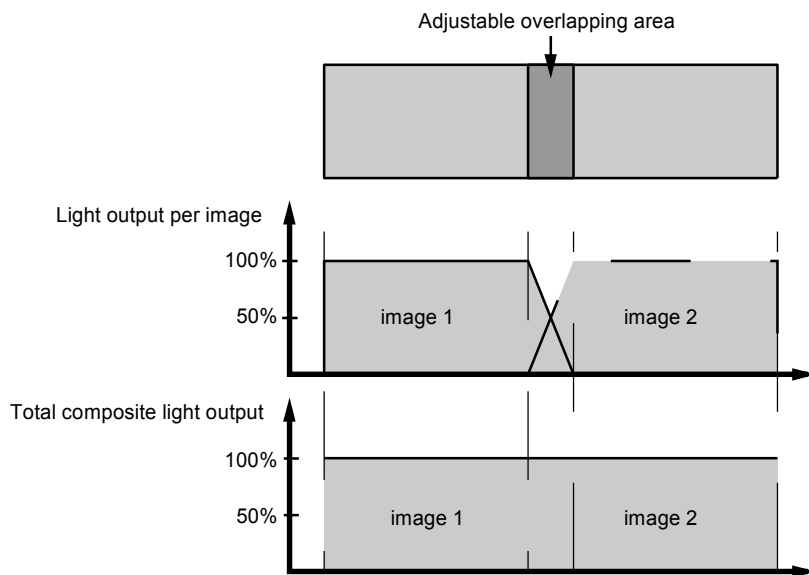

Image 6-115
Light modulation in Soft Edge

6.9.10.2 Soft Edge overlap zone (horizontal Soft Edge)

Definitions

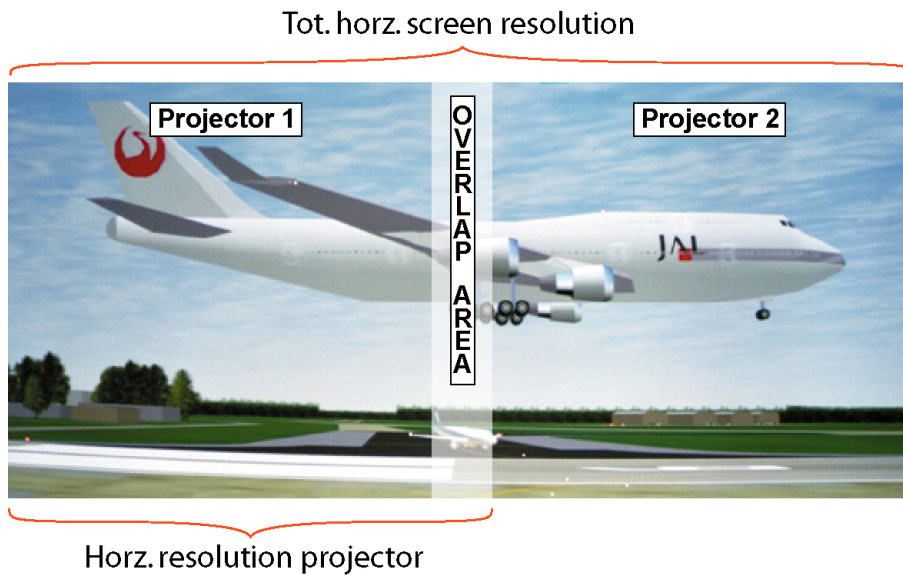

Image 6-116
Scenergix set up

Overlap : number of pixels that overlap

Horizontal resolution of 1 projector : 1400 for SXGA+ projectors.

Total horizontal screen resolution : [(horizontal resolution of 1 projector) x 2] minus overlap.

Horizontal Resolution source : number of active pixels of the source.

Adjustment of Active pixels (Pact) of the first projector

1. Go to File → Edit menu of first projector.
2. Enter value for horizontal active (= Pact) as follows :

$$\text{Pact} = [(\text{Horz. resolution of 1 projector}) / (\text{Total horz. screen resolution})] \times (\text{horz. resolution source})$$
3. Horizontal start (= Pstart) remains the same.

Adjustment of Active pixels (Pact) of second projector

1. Go to File → Edit menu of second projector.
2. Enter value for horizontal active (= Pact) as follows :

$$\text{Pact} = [(\text{Horz. resolution of 1 projector}) / (\text{Total horz. screen resolution})] \times (\text{horz. resolution source})$$
3. Horizontal start (= Pstart) = original start + [(Horz. resolution source) minus (newly calculated Pact)]

Example

Horizontal resolution source : 1600 pixels

horizontal resolution projector 1 & 2 : 1024 pixels

Overlap : 100 pixels

Total horizontal screen size in pixels : 1948 pixels

Pact projector 1 = [(1024 / 1948)] x 1600 = 841 pixels

Pact projector 2 = [(1024 / 1948)] x 1600 = 841 pixels

Pstart projector 2 = Pstart projector 1 + (1600 – 841)

6.9.10.3 Soft Edge border adjustment

What can be done with the Soft Edge border menu?

Within this menu the width of the blending zone is set up.

How to select a border?

1. Press **MENU** to activate the menu bar.

6. Advanced

- Press → to select the *Display setup* item.

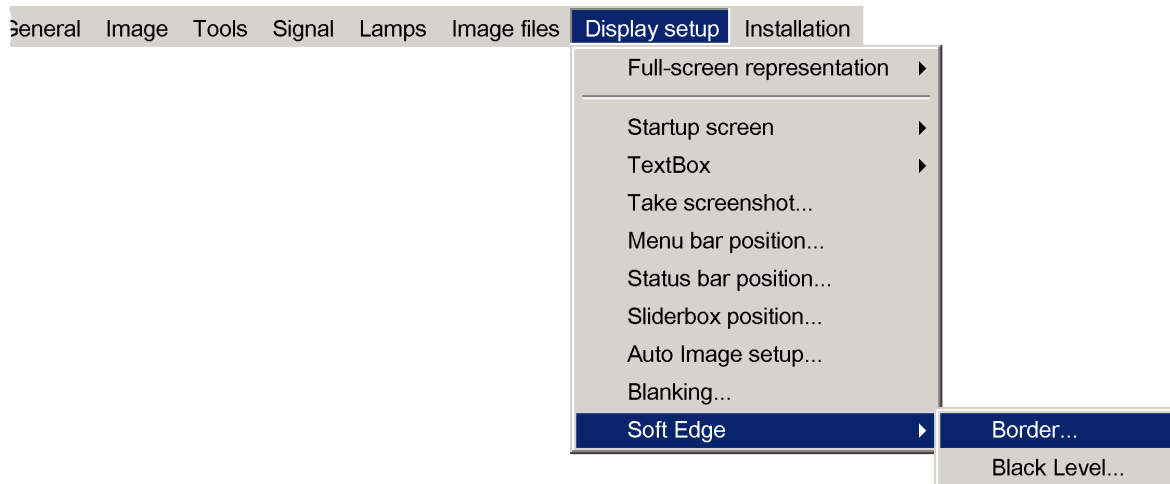

Image 6-117

- Press ↓ to pull down the *Display setup* menu.
- Use ↑ or ↓ to select *Soft Edge*.
- Press → to select the *Soft Edge* item.
- Use ↑ or ↓ to select *Border*.
- Press **ENTER** to select.

A dialog box will be displayed. The actual Soft Edge border will be displayed.

- Use ↑ or ↓ to select the desired adjustment.

Adjusting with the arrow keys.

- When on an adjustment, use the → or ← key to move the border line to the desired position.

The border line will move in the desired direction and the light output in the overlap area will be adapted to.

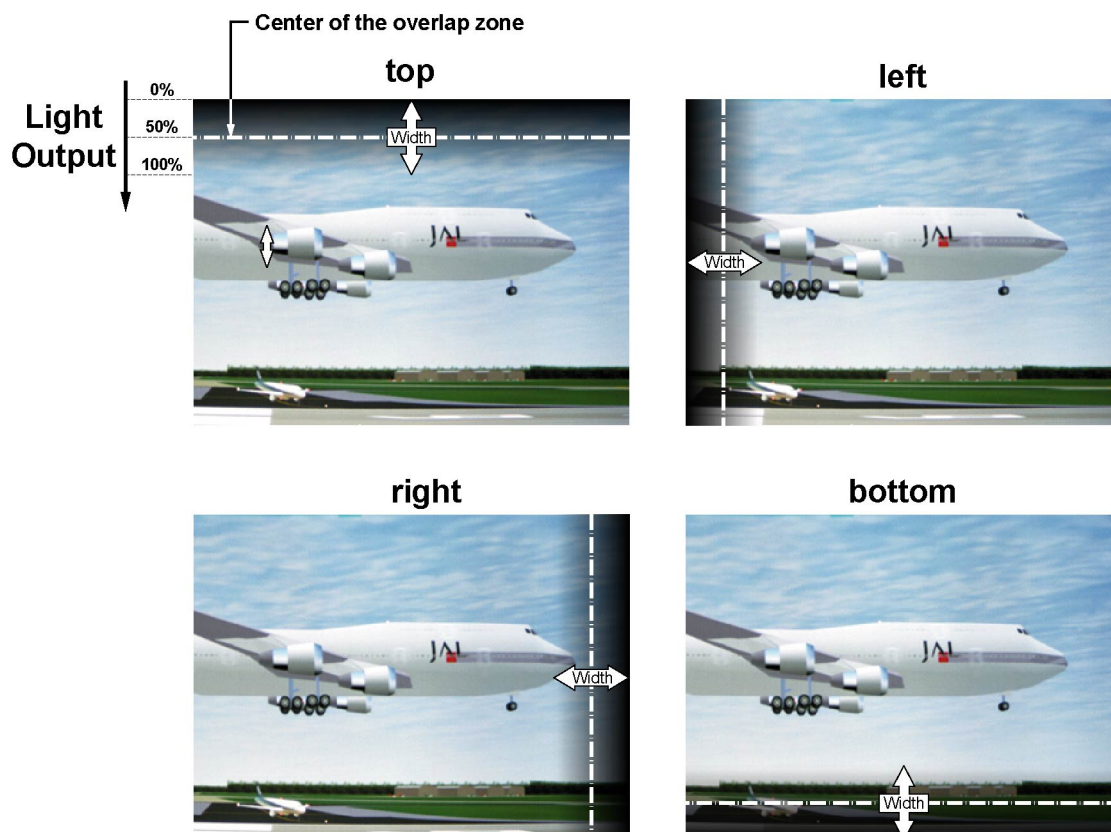

Image 6-118
Width selections

Set first the width of the first projector and repeat for the second one.

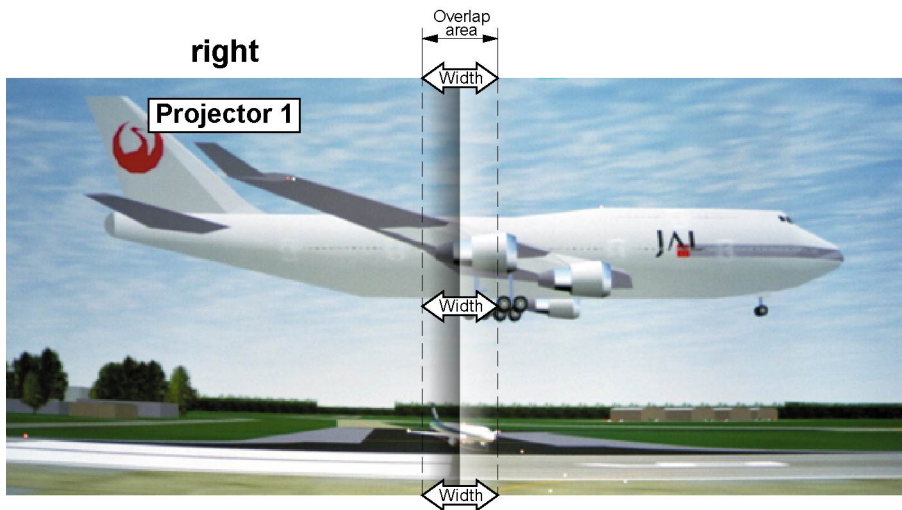

Image 6-119
Width set up for projector 1

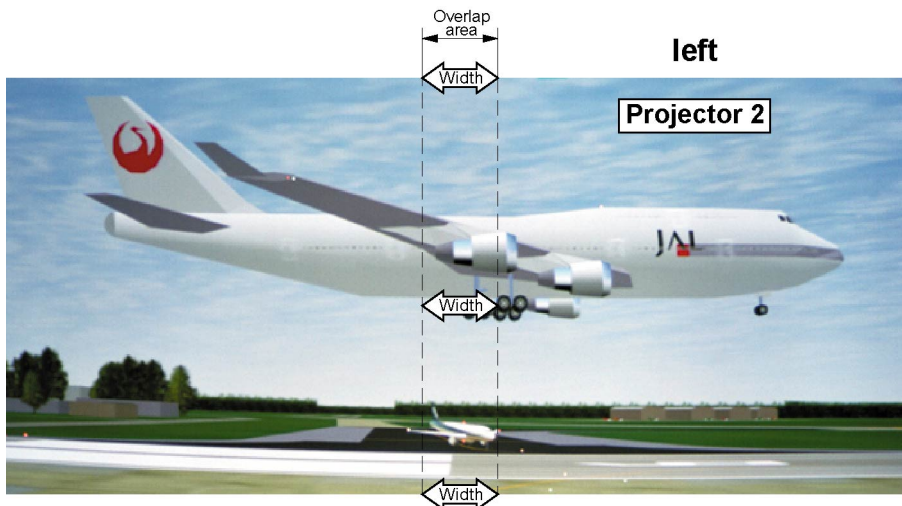

Image 6-120
Width set up for projector 2

Adjusting by entering the exact values.

1. When on an adjustable item, the input box background will be colored. Press **ENTER**.
The value will change to a 3 digit value and the first digit is selected.
2. Enter a value with the digit keys on the remote control.
The cursor jumps automatically to the next digit.
3. Press **ENTER** to activate the new value.



Use reset to return to the default settings.

6.9.10.4 Black level of the images

Why

For dark images, the overlap zone will be brighter than the rest of the images. Therefore we can rise the black level of the remaining image (excluding the overlap zone)

How to adjust

1. Press **MENU** to activate the menu bar.
2. Press → to select the *Display setup* item.

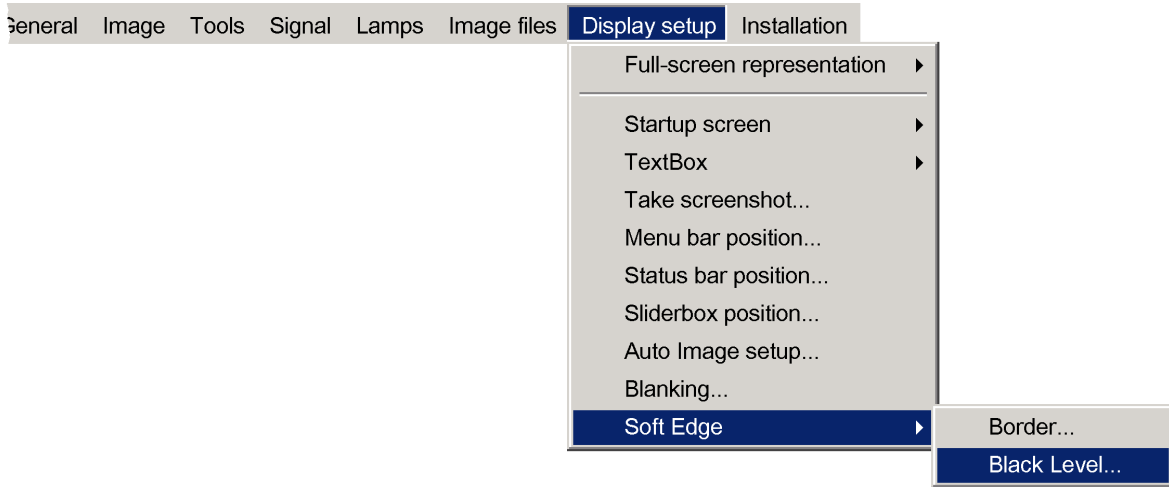

Image 6-121

3. Press ↓ to pull down the *Display setup* menu.
4. Use ↑ or ↓ to select *Soft Edge*.
5. Press → to select the *Soft Edge* item.
6. Use ↑ or ↓ to select *Black level*.
7. Press **ENTER** to select.

A dialog box will be displayed on a black level background.

Adjust the black level of area A until the black level of area A, B and C or equal (area C should be adjusted on the second projector).

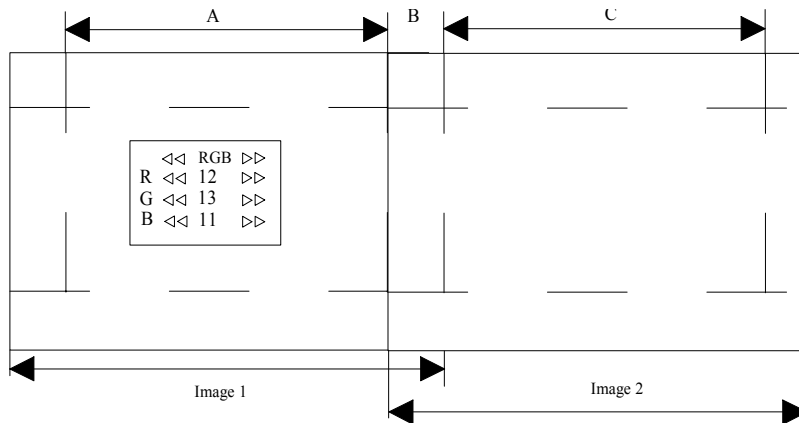

Image 6-122
Black level adjustment

- Use the up or down arrow key to select the adjustment (All, Red, Green or Blue)
- Use the left or right arrow key to select the adjustment direction and speed.
- Press **ENTER** to increment or decrement the value.

6.10 Installation

Overview

- Lens adjustments
- Security
- Change password

6.10.1 Lens adjustments

What can be done ?

Motorized lenses can be adjusted in the installation menu or via the dedicated keys on the remote.

The following parameters can be adjusted:

- Zoom
- Focus
- Shift (also for non motorized lenses)

How to Zoom/focus or shift ?

1. Press **MENU** to activate the Toolbar
2. Press **→** to select the *Installation*
3. Press **↓** to Pull down the *Installation* menu
4. Use **↑** or **↓** to select *Lens adjustment*

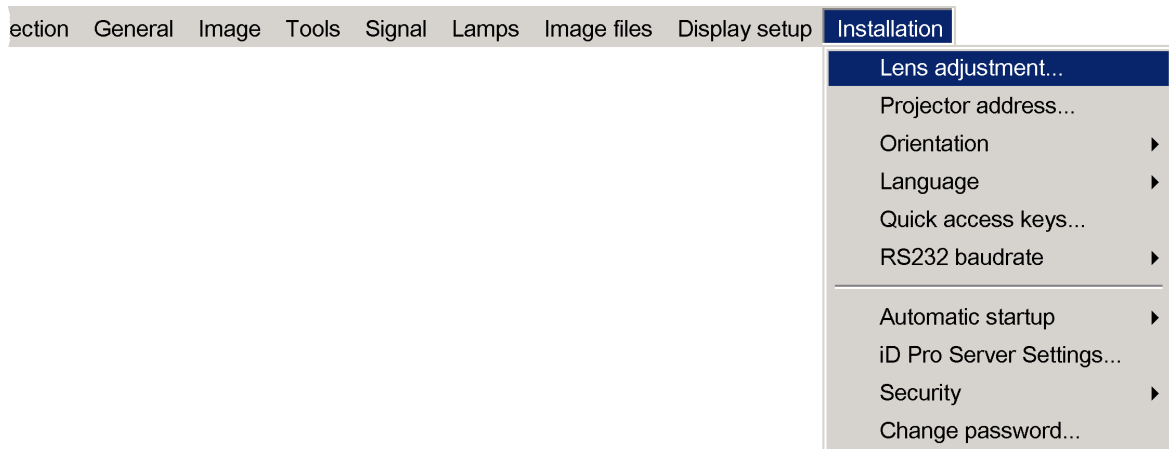

Image 6-123

5. Press **ENTER**

A textbox appears on the screen, follow the instructions.

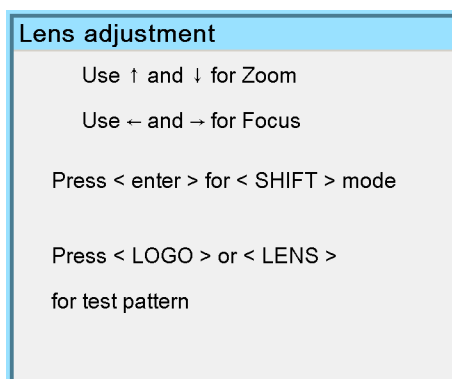

Image 6-124

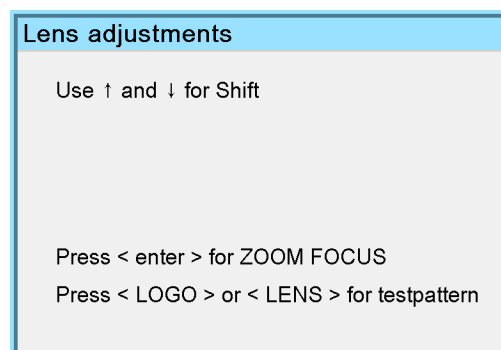

Image 6-125

6.10.2 Security

What can be done ?

A security function is implemented in the projector and allows a protection against theft.

A PIN code allows the user to lock the projector in case of wrong code entry.

The PIN code must be entered at each start up (Power ON), entering three times a wrong number triggers a wait cycle of 15 minutes, the second 3 wrong codes a wait cycle of 30 minutes, 1 hour, ...

The security mode can be enabled or disabled.

How to activate the security mode ?

1. Press **MENU** to activate the Tool bar
2. Press → to select the *installation* item
3. Press ↓ to Pull down the menu
4. Use ↑ or ↓ to select *Security*

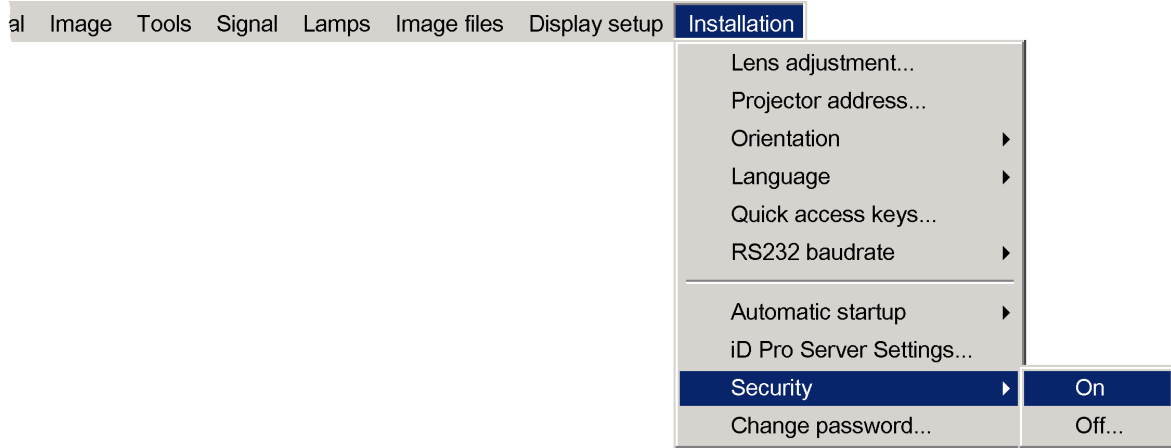

Image 6-126

5. Press → to open the menu
6. Use ↑ or ↓ to select *ON*
7. Press **ENTER**

A dialog box is displayed

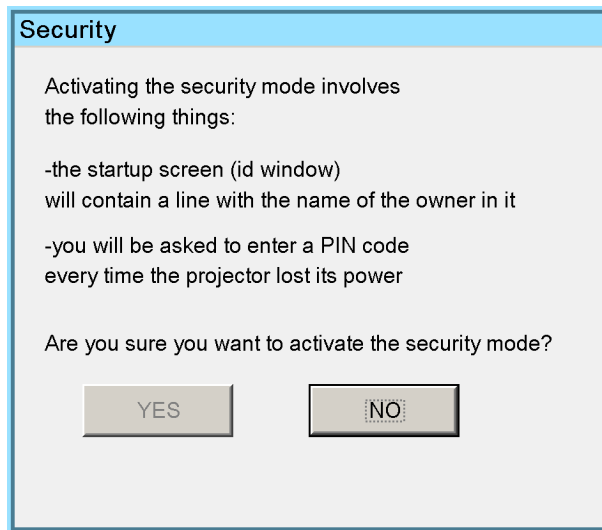

Image 6-127

8. Use the arrow keys to select YES and press **ENTER** to confirm

A dialog box is displayed

Enter your name, company name,... (this information is displayed in the identification menu)

Image 6-128

9. Press **ACCEPT**

A dialog box is displayed.

Enter the PIN code, and confirm it.

Image 6-129

An informative text box is then displayed. Press **ENTER** or **BACK** to escape.

Image 6-130

How to disable the security mode ?

1. Press **MENU** to activate the Tool bar
2. Press **→** to select the *installation* item
3. Press **↓** to Pull down the menu
4. Use **↑** or **↓** to select *Security*
5. Press **→** to open the menu
6. Use **↑** or **↓** to select *OFF*
7. Press **ENTER**

A dialog box is displayed

8. Enter your PIN code

The security mode is now disabled

6.10.3 Change password

How to change the password ?

1. Press **MENU** to activate the Tool bar
2. Press → to select the *Installation* item
3. Press ↓ to Pull down the *Installation* menu
4. Use ↑ or ↓ to select *Change password*

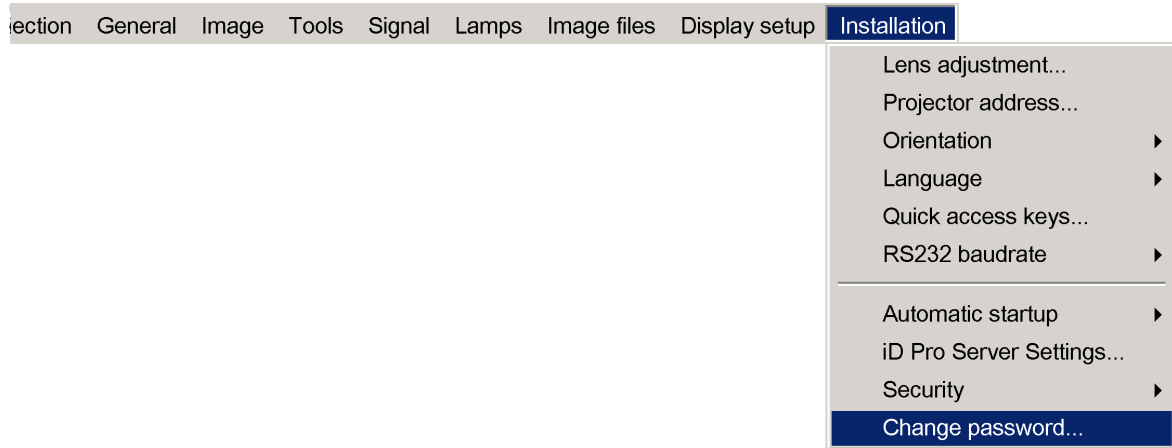

Image 6-131

5. Press **ENTER**

A dialog box is displayed.

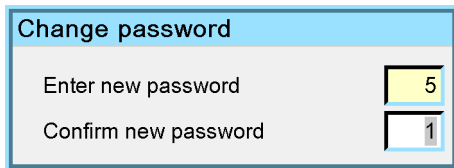

Image 6-132

6. Use ← or →, the numeric keys on the remote, or the keypad to enter and confirm the new password.

Each character is displayed as an asterisk.



The new password is accepted if the new password and the confirmed password coincide.



If the password is forgotten contact a Barco authorized technician.

7. IMAGE FILES

7.1 Table overview

Table overview

The following standard image files are pre-programmed in the projector.

Name ⁴	Resolution ⁵	Fvert Hz ⁶	FHor kHz ⁷	Fpix MHz ⁸	Ptot ⁹	Pact ¹⁰	Ltot ¹¹	Lact ¹²
1600_48V	1600x600i	48,040	62,500	135,000	2160	1600	651	600
CGA	640x200i	59,924	15,700	14,318	912	640	262	200
COMPUSC4	1024x480i	29,945	30,694	39,779	1296	1024	512	480
DOS1_70	720x400	70	31,500	28,350	900	720	449	400
DOS3_56	640x400	56	24,800	21,030	848	640	440	400
DOS4_85	640x400	85	37,860	31,500	832	640	445	400
ED	735x480	59,943	31,470	28,638	910	735	525	480
EGA	640x350	59,702	21,851	16,257	744	640	366	350
ESVGA_75	832x624	73	47,900	53,648	1120	832	660	624
EXGA_60	1152x864	60	54,900	79,934	1456	1152	916	864
EXGA_80	1152x864	80,000	76,499	110,159	1140	1152	958	864
EXGA_85	1152x864	85,000	77,202	121,671	1576	1152	907	864
EXGA1_70	1152x864	70	63,800	94,424	1480	1152	912	864
EXGA1_75	1152x864	75	67,499	107,999	1600	1152	900	864
EXGA2_70	1152x864	70	66,098	99,941	1512	1152	945	864
EXGA2_75	1152x864	75	75,199	110,092	1464	1152	1002	864
FMR	640x400i	42,323	36,440	28,570	784	640	431	400
GE_50	640x400	50	31,200	44,928	1440	1163	625	522
GE_60	1085x480	60	30,700	41,261	1344	1085	512	480
hd_1080i	1920x540	60	33,750	74,249	2200	1920	563	540
hd_24p	1920x1080	24,000	27,000	74,000	2750	1920	1125	1080
hd_24sf	1950x540	48,000	27,000	74,000	2750	1950	562	540
hd_25i	1920x540	50,000	28,125	74,000	2640	1920	562	540
hd_25p	1920x1080	25,000	28,125	74,000	2640	1920	1125	1080
hd_30p	1920x1080	30,000	33,750	74,000	2200	1920	1125	1080
hd_60p	1280x720	60,000	45,000	74,000	1650	1280	750	720
INTER_GR	1184x886	67,170	61,796	92,941	1504	1184	920	886
IQPC_SXGA_2	1366x1024	59	62,933	106,230	1688	1366	1067	1024
IQPC_SXGA_D	1280x1024	60	63,857	107,791	1688	1280	1063	1024
IQPC_XGA_1	1024x768	61	49,005	65,863	1344	1024	807	768

4. Name: name of file, contains the settings.

5. Resolution: image resolution, when followed by ..i means interlaced.

6. Fvert Hz: vertical frame frequency of the source

7. FHor kHz: horizontal frequency of the source

8. Fpix MHz: pixel frequency

9. Ptot : total pixels on one horizontal line.

10. Pact: active pixels on one horizontal line.

11. Ltot: total lines in one field

12. Lact: active lines in one field.

7. Image files

Name ⁴	Resolution ⁵	Fvert Hz ⁶	FHor kHz ⁷	Fpix MHz ⁸	Ptot ⁹	Pact ¹⁰	Ltot ¹¹	Lact ¹²
IQPC_XGA_2	1024x768	60	48,485	65,164	1344	1024	807	768
IQPC_XGA_D	1024x768	61	49,005	65,863	1344	1024	806	768
MAC_3	512x384	60,147	24,480	15,667	640	512	407	384
MAC_4	560_384	60,147	24,480	17,234	704	560	407	384
MAC_5	512x342	60,158	22,259	16,670	704	512	370	342
MAC_6	832x624	74,546	49,722	57,280	1152	832	667	624
MAC_7	1024x768	74,907	60,150	80,000	1330	1024	803	768
MAC_LC	640x480	66,619	34,975	31,338	896	640	525	480
MAC_POR	640x870	74,996	68,846	57,280	932	640	918	870
METH_BOOT1	720x400	70	31,500	28,350	900	720	448	400
METH_BOOT2	640x480	59	31,000	24,800	800	640	524	480
MXGA_100	1152x864	100	92,997	145,820	1568	1152	930	864
NTSC	675x240	60	15,748	13,512	858	675	263	240
NTSC_LIMO_x2	834x482	60	31,496	32,252	1024	834	525	482
NTSC_LIMO_x3	834x715	60	46,646	47,766	1024	834	778	715
NTSC_LIMO_x4	834x961	60	62,992	64,504	1024	834	1050	961
PAL	675x286	50	15,625	13,500	864	675	313	286
PAL_LIMO_x2	834x574	50	31,250	32,000	1024	834	626	574
PAL_LIMO_x3	834x850	50	46,296	47,407	1024	834	926	850
PAL_LIMO_x4	834x1146	50	62,500	64,000	1024	834	1250	1146
PAM500	640x400	60,000	26,400	22,810	864	640	440	400
PAM800	1120x375i	44,936	36,443	50,000	1372	1120	406	375
PC98_2	1120x375i	39,994	32,835	47,840	1457	1120	411	375
PC98_3	1120x750	60,000	50,000	78,569	1571	1120	833	750
S1152_66	1152x900	66,004	61,846	94,500	1528	1152	937	900
S1152_76	1152x900	76,637	71,809	108,000	1504	1152	937	900
S1600_67	1600x1280	67	89,286	200,000	2240	1600	1334	1280
SDI_625	675x278i	25,000	15,625	13,500	864	720	313	278
SDI_525	675x240i	29,970	15,734	13,500	858	720	263	240
SG_50	1600x1200	50,000	62,500	130,313	2085	1600	1250	1200
SG_60_1	1280x1024	60,000	63,900	107,352	1680	1280	1065	1024
SG_60_2	1024x768	60,000	48,780	64,390	1320	1024	813	768
SG_60_3	960x680	60,000	43,200	54,432	1260	960	720	680
SG_60_4	1600x1200	60,000	75,000	156,375	2085	1600	1250	1200
STOR_100	764x287	100	31,300	30,361	970	764	313	287
STOR_120	810x247	119	31,300	30,361	970	810	263	247
STOR_50	1024x512	50	31,300	40,064	1280	1024	625	512
STOR_60	1024x512	60	31,300	40,064	1280	1024	525	512
SUNNEWS67	1280x1024	67,189	71,691	117,000	1632	1280	1067	1024
SUNNEWS76	1280x1024	76,107	81,130	135,000	1664	1280	1066	1024
SUNXGA60	1024x768	59,984	48,287	64,125	1328	1024	805	768

Name ⁴	Resolution ⁵	Fvert Hz ⁶	FHor kHz ⁷	Fpix MHz ⁸	Ptot ⁹	Pact ¹⁰	Ltot ¹¹	Lact ¹²
SUNXGA70	1024x768	70,041	56,596	74,250	1312	1024	808	768
SUNXGA77	1024x768	77,069	62,040	84,375	1360	1024	805	768
SUP_MAC	1024x768	60,000	48,780	63,999	1312	1024	813	768
SVGA_56V	800x600	56,250	35,156	36,000	1024	800	625	600
SVGA_60V	800x600	60,317	37,879	40,000	1056	800	628	600
SVGA_72_1	800x600	72,084	48,080	50,003	1040	800	666	600
SVGA_72_2	800x600	72,084	48,080	50,003	1040	800	667	600
SVGA_75	800x600	75,000	46,875	75,000	1056	800	625	600
SVGA_85	800x600	85,000	53,635	56,250	1048	800	631	600
SXGA_72_1	1280x1024	72	76,699	128,854	1680	1280	1061	1024
SXGA_72_2	1280x1024	72	76,970	130,080	1690	1280	1069	1024
SXGA_75	1280x1024	75	79,974	134,997	1688	1280	1066	1024
SXGA_76	1280x1024	76	81,103	134,955	1664	1280	1066	1024
SXGA_85	1280x1024	85	91,149	157,506	1728	1280	1072	1024
SXGA_L	1280x1024	60	62,500	84,000	1344	1280	1041	1024
SXGA+_60	1280x1024	60	63,980	107,997	1688	1280	1066	1024
SXGA2_60	1280x960	60	59,999	107,998	1800	1280	1000	960
SXGA2_85	1280x960	85	85,940	148,505	1728	1280	1011	960
SXGA50	1280x1024	50	52,351	88,368	1688	1280	1047	1024
SXGA60v	1280x1024	60	63,658	110,001	1728	1280	1056	1024
SXGAP_70	1024x1280	70	92,902	133,779	1440	1024	1326	1280
SXGAP1_60	1024x1280	60	77,700	83,916	1080	1024	1297	1280
SXGAP2_60	1024x1280	60	79,498	110,661	1392	1024	1325	1280
UXGA_60	1600x1200	60	75,002	162,004	2160	1600	1250	1200
UXGA_65	1600x1200	65	81,248	175,496	2160	1600	1250	1200
UXGA_70	1600x1200	70	87,497	188,993	2160	1600	1250	1200
UXGA_75	1600x1200	75	93,747	202,494	2160	1600	1250	1200
UXGA_85	1600x1200	85	106,247	229,494	2160	1600	1250	1200
UXGA_L	1600x1200	60	72,801	119,977	1648	1600	1216	1200
UXGAP1_60	1200x1600	59	95,804	119,946	1252	1200	1620	1600
UXGAP2_60	1200x1600	60	99,404	163,817	1648	1200	1656	1600
VGA_60	640x480	60	31,326	25,061	800	640	525	480
VGA_66	640x480	67	35,100	30,326	864	640	525	480
VGA_72	640x480	73	37,860	31,500	832	640	520	480
VGA_75	640x480	75,000	37,500	31,500	840	640	500	480
VGA1_85	640x480	85,000	43,369	36,000	832	640	509	480
VGA2_85	720x400	85,000	37,900	35,475	936	720	446	400
VGA75ISO	640x480	75,000	39,375	31,500	800	640	525	480
VIDEO525	1302x239i	29,970	15,734	32,207	1302	1024	263	239
VIDEO625	1024x278i	25,000	15,625	31,984	1310	1024	313	278

7. Image files

Name ⁴	Resolution ⁵	Fvert Hz ⁶	FHor kHz ⁷	Fpix MHz ⁸	Ptot ⁹	Pact ¹⁰	Ltot ¹¹	Lact ¹²
XGA_43	1024x384	87	35,500	44,872	1264	1024	409	384
XGA_60	1024x768	60,000	48,360	64,996	1344	1024	806	768
XGA_70_1	1024x768	70,000	56,475	74,999	1328	1024	806	768
XGA_70_2	1024x768	70,000	57,052	78,047	1368	1024	815	768
XGA_72	1024x768	71,955	58,140	80,000	1376	1024	808	768
XGA_75_1	1024x768	75	60,024	78,752	1312	1024	800	768
XGA_75_2	1024x768	76	61,080	86,000	1408	1024	806	768
XGA_85	1024x768	85,000	68,680	94,500	1376	1024	808	768
XGA_EOS	1024x768	63,000	50,000	67,200	1344	1024	796	768
XGA75_GS	1024x768	74,534	59,701	79,284	1328	1024	801	768
SXGA_60	1280x1024	60	63,980	107,997	1688	1280	1066	1024
SXGA+_60_2	1400x1050	60	65,574	122,230	1864	1400	1089	1050
SXGA+_60_3	1400x1050	60	65,104	122,396	1880	1400	1085	1050

Table 7-1

8. TROUBLESHOOT

8.1 Using the OSD

What can be done ?

The projector bus allows the diagnostic of different hardware components divided in two main groups.

- I²C diagnostics : a number of internal electronic boards can be diagnosed and a graphical interface shows whether an error is
- Lamps and power supply : lamp temperature and power related failures are logged and can be checked at any time.

How to display the I²C diagnostics menu ?

1. Press **MENU** to activate the Tool bar
2. Press → to select the *Tools* item
3. Press ↓ to Pull down the *Tools* menu
4. Use ↑ or ↓ to select *Diagnostics*
5. Press → to pull down the menu
6. Press **ENTER** to select I²C

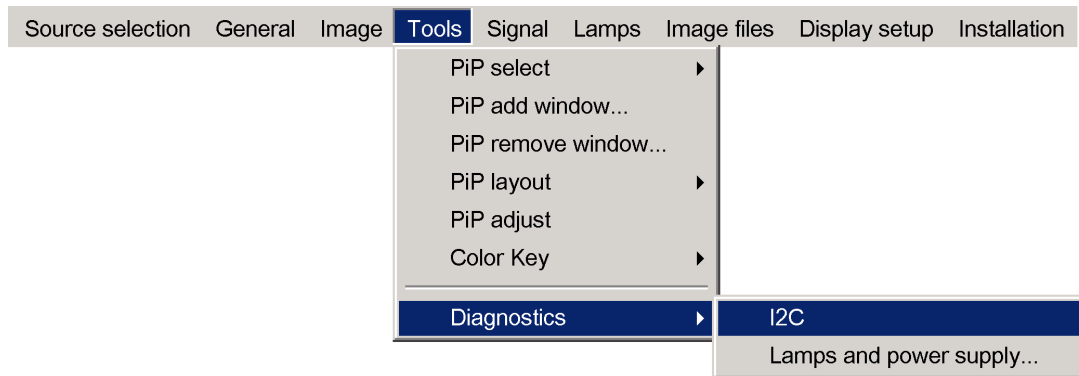

Image 8-1

A text box is displayed

How to display the Lamps and power supply diagnostic menu ?

1. Press **MENU** to activate the Tool bar
2. Press → to select the *Tools* item
3. Press ↓ to Pull down the *Tools* menu
4. Use ↑ or ↓ to select *Diagnostics*
5. Press → to pull down the menu
6. Press **ENTER** to select *Lamps and power supply*

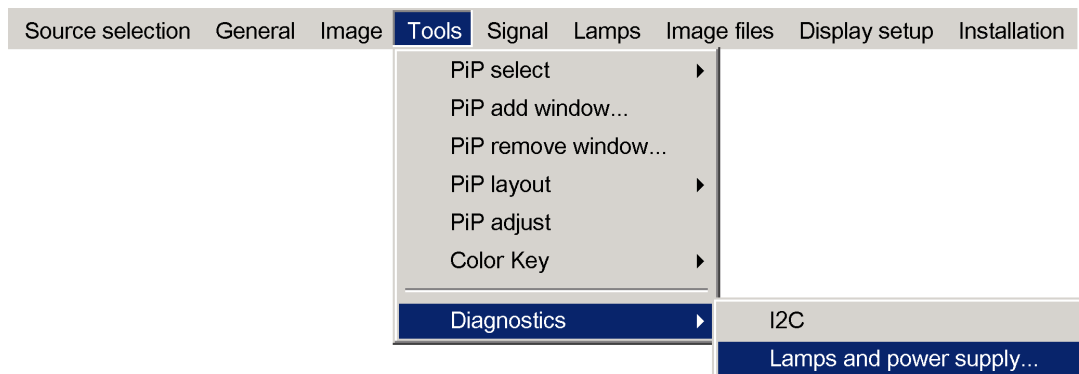

Image 8-2

8. Troubleshoot

A text box is displayed

Lamps and power supply	
Projector runtime	Description
65	: lamp 1 error
703	: Ambient temperature error
1144	: lamp 2 error

Image 8-3



For Barco certified service technicians only: For more information on possible hardware failures refer to the Service Manual.

9. MAINTENANCE

9.1 Cleaning the lens



To minimize the possibility of damage to optical coatings, or scratches to lens surfaces, we have developed recommendations for cleaning. **FIRST**, we recommend you try to remove any material from the lens by blowing it off with clean, dry deionized air. **DO NOT** use any liquid to clean the lenses.

Necessary tools

Toraysee™ cloth (delivered together with the lens kit). Order number : R379058.

How to clean the lens ?

1. Always wipe lenses with a CLEAN Toraysee™ cloth.
 2. Wipe lenses in a one single direction.
Warning: *Do not wipe back and forwards across the lens surface as this tends to grind dirt into the coating.*
 3. Do not leave the cleaning cloth in either an open room or lab coat pocket, as doing so can contaminate the cloth.
 4. If smears occur when cleaning lenses, replace the cloth. Smears are the first indication of a dirty cloth.
-



CAUTION: Do not use fabric softener when washing the cleaning cloth or softener sheets when drying the cloth.

Do not use liquid cleaners on the cloth as doing so will contaminate the cloth.



Other lenses can also be cleaned safely with this Toraysee™ cloth.

9.2 Cleaning the dustfilters

Overview

- Dustfilters
- Cleaning

9.2.1 Dustfilters

Location of the filters

There are 4 filters located at different positions

1. Filter1: Lamp 1
2. Filter2 : Lamp 2
3. Filter 3 : X-Cube filter
4. Filter 4 : Input filter

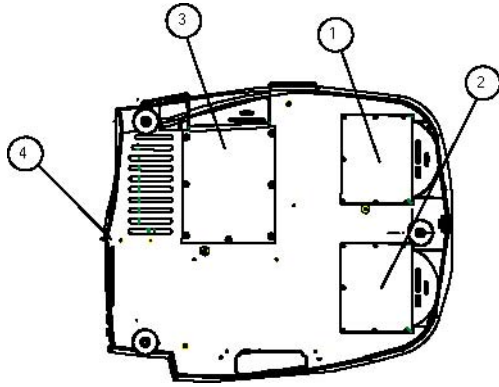

Image 9-1
location of the filters

- 1 lamp filter 1
- 2 lamp filter 2
- 3 x-cube filter
- 4 input filter

9.2.2 Cleaning

How to clean the dustfilters ?

1. Place the projector so as to access easily the filter to be cleaned
2. Push the handle downwards to unlock the filter.

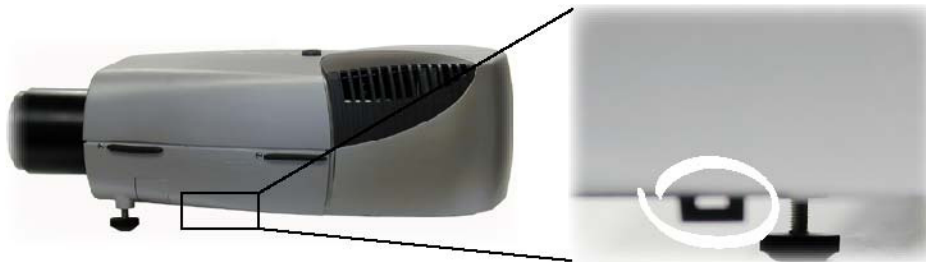

Image 9-2
Location of the x-cube filter and its handle

3. Slide out the filter



Image 9-3
Lamp filter removal



Image 9-4
lamp & X-Cube filters removed

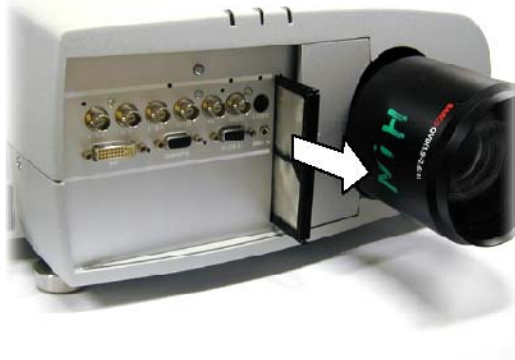

Image 9-5
Input filter removal



Image 9-6
Input filter removed

4. Clean the dust filter with a dry cloth.
5. Re-insert the dust filter by sliding it back in the filter housing.



If the airflow is falling under a predetermined threshold value a warning will be displayed on the screen.

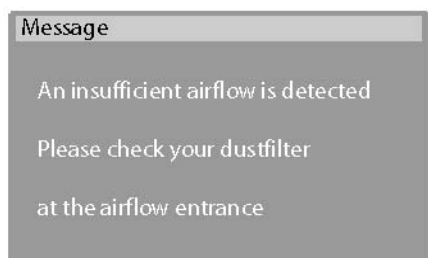

Image 9-7

At that time it is strongly recommended to replace or clean the dustfilter under the X-cube. Failing to do so, will strongly reduce the lifetime of the LCD's and the analyzers.

The manufacturer reserves itself the right to refuse warranty repair if the projector was working with dirty dustfilters.

9.3 The UHP Lamp

9.3.1 Reset lamp runtime

9.3.1.1 Reset runtime

When to reset the lamp runtime ?

The lamp runtime should only be reset when placing a new lamp.



WARNING: Lamp runtime reset as well as the lamp replacement can only be done by a Barco authorized technician.

How to reset the lamp runtime in the iQ/iD ?

1. Press **MENU** to activate the Tool bar
2. Press **→** to select the *Lamp* item
3. Press **↓** to Pull down the *Lamp* menu
4. Use **↑** or **↓** to select *Reset runtime*
5. Press **→** to pull down the menu
6. Use **↑** or **↓** to select the lamp to be reset

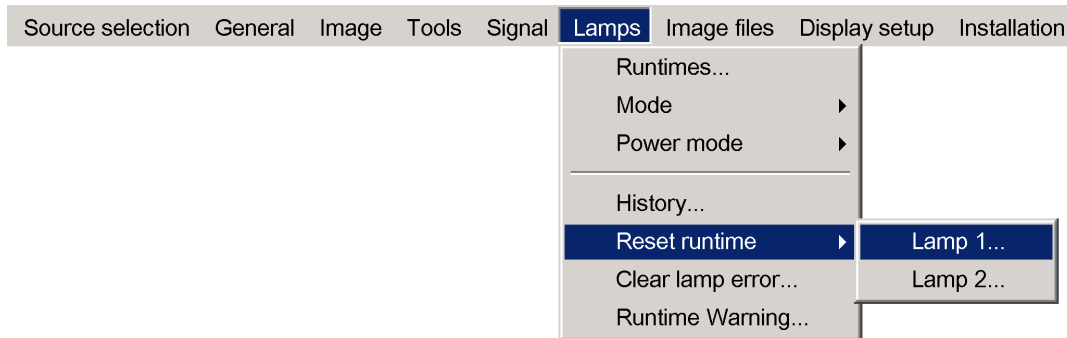

Image 9-8

7. Press **ENTER**

A dialog box is displayed

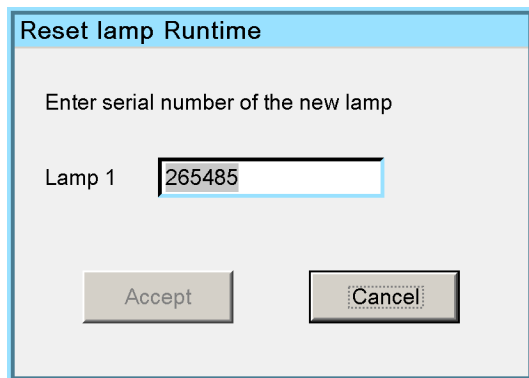

Image 9-9

8. Use **←** or **→**, the numeric keys on the remote, or the keypad to change the serial number of the lamp (serial number 0000000 will not be accepted).



WARNING: Lamp runtime reset as well as the lamp replacement can only be done by a Barco authorized technician.

How to reset the lamp runtime in the SIM5Plus?

1. Press **MENU** to activate the Tool bar
2. Press → to select the *Lamp* item
3. Press ↓ to Pull down the *Lamp* menu
4. Use ↑ or ↓ to select *Reset runtime*
5. Press → to pull down the menu
6. Use ↑ or ↓ to select the lamp to be reset
7. Press **ENTER**

A dialog box is displayed

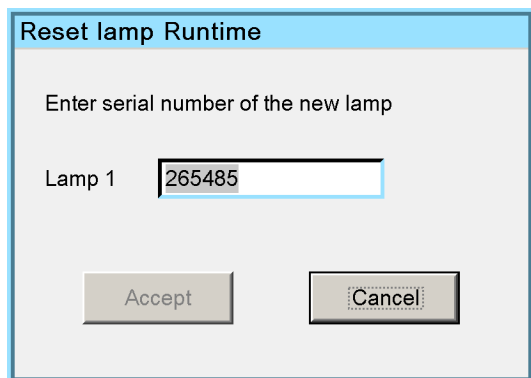

Image 9-10

8. Use ← or →, the numeric keys on the remote, or the keypad to change the serial number of the lamp (serial number 0000000 will not be accepted).



WARNING: Lamp runtime reset as well as the lamp replacement can only be done by a Barco authorized technician.

9.3.2 Removing the lamp unit(s)

What has to be done ?

1. The lamp power connection has to be disconnected.
2. The lamp unit has to be removed.



Perform the procedure for both lamps if necessary.

In this procedure lamp1 is replaced, the procedure being the same for lamp2.

How to remove the lamp unit ?

1. Disconnect the lamp

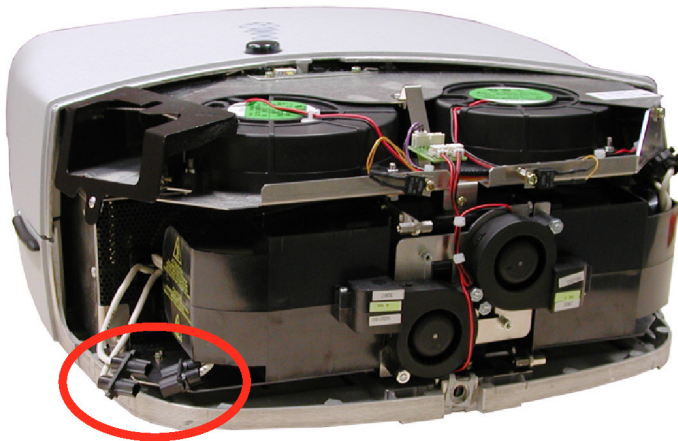

Image 9-11

2. Pull the lamp locking handle to unlock the lamp

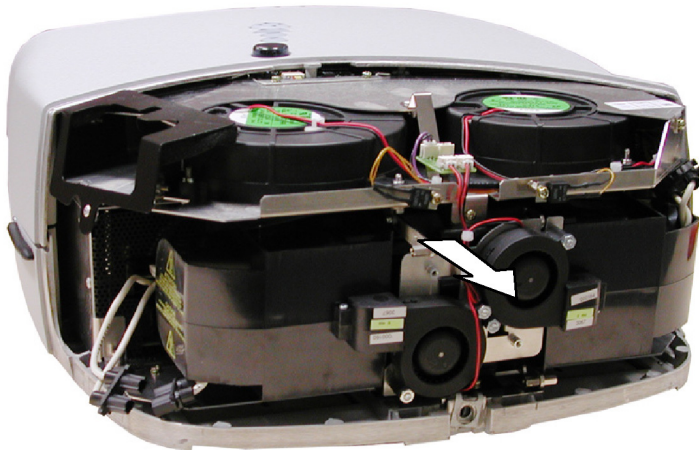

Image 9-12
Unlock the lamp

3. Take out the lamp unit

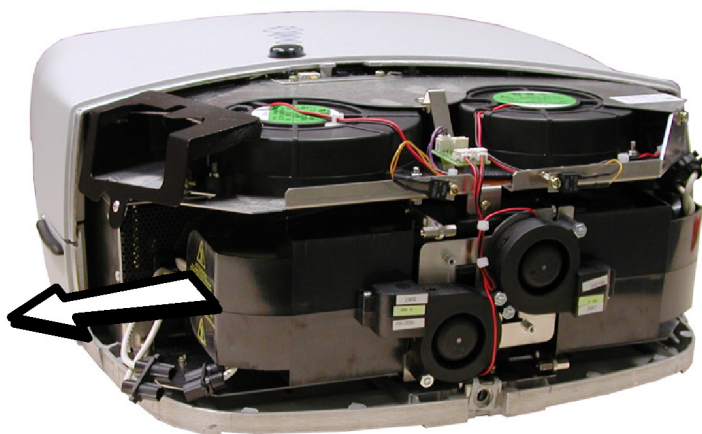
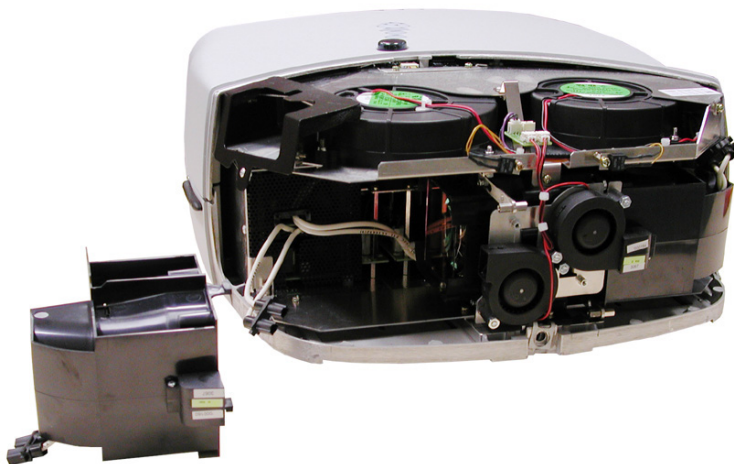

Image 9-13

Image 9-14
Lamp removed

9.3.3 Mounting the lamp unit(s)

What has to be done ?

1. The lamp has to be mounted
2. The lamp has to be connected.



Perform the procedure for both lamps if both lamps have to be replaced.

In this procedure lamp 1 is replaced, the procedure being the same for lamp 2.

How to mount the lamp unit ?

1. Place carefully the lamp against the frame
2. Push the lamp inwards and push in the lamp locking to lock the lamp
3. Connect the lamp



CAUTION: Always insure that the lamp is well mounted, locked and in line with the optical frame. If the lamp is misaligned, this will cause damage (by UV radiation) to the optical frame !



In some projectors, the lamp mounting mechanism may be more tight . Handle always in a gentle way, never force the lamp locking mechanism, as this may misalign the lamp and damage the projector (see Caution above).

GLOSSARY

AGC

Automatic Gain Control: allows an automatic amplitude (gain) control of the incoming video signal

CEE7/7

European power plug to connect the power cord to the wall outlet.

Component Video

In Component Video the term component describes a number of elements that are needed to make up the video picture, these components are PR/Y/PB. A composite video signal on the other hand contains all the information needed for the color picture in a single channel of information

DVI

Digital Visual Interface is a display interface developed in response to the proliferation of digital flat panel displays.

The digital video connectivity standard that was developed by DDWG (Digital Display Work Group). This connection standard offers two different connectors: one with 24 pins that handles digital video signals only, and one with 29 pins that handles both digital and analog video. This standard uses TMDS (Transition Minimized Differential Signal) from Silicon Image and DDC (Display Data Channel) from VESA (Video Electronics Standards Association).

DVI can be single or dual link.

NEMA5

American power plug to connect the power cord to the wall outlet.

On-Axis projection

Projection where the projector is positioned so as to have the centre of the lens coinciding with the centre of the screen.

PiP

PiP stands for "Picture in Picture" and allows to display multiple windows containing each of them an image. The windows may be of the video or data type.

Reality(SXGA+)

Native resolution of the LCD panels = 1400 x 1050 pixels (4:3)

SDI

Serial Digital Interface

INDEX

A

address 29
 RCU 29
 Address 30
 Projector address 30
 Adjustments 107
 lens 107
 advanced 42
 source selection 42
 Advanced 41
 AGC 73
 Audio 22
 connection 22
 Auto Image 88
 AutoImage 99
 Setup 99
 automatic startup 34

B

Background 83
 blanking 70
 Blanking 100

C

cleaning 117
 lens 117
 Cleaning 117
 dustfilters 117
 color keying 81
 configuration 12
 connections 16
 source 16
 Connections 16–17, 23
 Communication 23
 Communications 23
 RS232 IN 23
 Input source connections 17
 facilities 17
 layers 17
 power connection 16

D

Diagnostics 82
 Digital 20–21
 DVI 20
 SDI 21
 Display Setup 96
 Dyancolor™ 65–66
 Interface 66
 L (Light Output) 65
 Dynacolor™ 61, 63, 66
 Basic 66
 Adjustment 66
 Start up 63

F

File 87, 89, 93–95
 copy 94
 delete 95
 edit 89
 load 87
 rename 93
 Filters 117–118
 cleaning 117–118
 location 117
 Full screen representation 96

G

Gain 73–74
 automatic control 73
 manual control 74
 General 44, 46–48
 audio 46
 Audio 46–47
 settings 47
 setup 46
 identification 48
 Standby Timer 46
 General menu 45
 freeze 45
 pause 45
 getting started 39
 adjust 39
 Getting started 37

I

Identification screen 48
 Image 49, 55, 61
 Dynacolor™ 61
 resolution 55
 image files 95
 forced file load 95
 Image files 111
 Input 18–22
 Input source connection 18–22
 5-Cable input 18
 Audio 22
 Composite Video input 19
 computer input 21
 DVI 20
 S-Video input 20
 SDI 21
 input balance 70
 installation 7, 10, 13, 29, 31
 address 29
 guidelines 7
 lens adjustments 31
 positioning 13
 RCU 10
 Installation 9, 106
 Installation guidelines 7
 guidelines 7
 Safety 7
 safety warnings 7

L

lamp 84, 120–121, 123
 mounting 123
 removing 121
 runtime reset iQ 120
 Lamp history 86
 Lamp mode 84
 Language 33
 Layers 17
 input 17
 lens 11, 117
 cleaning 117
 installation 11
 range 11
 Lens 11–12, 107
 Formulas 12
 lens adjustments 107
 removing 11
 Lenses 11
 installation 11
 Local keypad 25

M

- Maintenance 117
- Menu 30–31, 33–34, 41, 49–53, 57–58, 73–80, 82–84, 86–87, 89, 93–99, 107, 110, 120
 - Image files menu 87, 89, 93–95
 - copy file 94
 - delete file 95
 - edit file 89
 - load file 87
 - rename file 93
 - Image menu 49–53, 57–58, 73–74
 - AGC on video 73
 - aspect ratio 53
 - Brightness 51
 - color 51
 - color temperature 58
 - contrast 50
 - filmmode detection 58
 - Gamma 52
 - Keystone 57
 - manual gain control 74
 - noise reduction 53
 - phase 52
 - settings 49
 - sharpness 52
 - Tint 51
 - Installation menu 30–31, 33–34, 96–99, 107, 110
 - AutoImage Setup 99
 - change password 110
 - Full screen representation 96
 - language 33
 - lens adjustments 107
 - projector address 30
 - projector orientation 31
 - Quick access keys 34
 - Sliderbox position 99
 - Startup screen 97
 - Take screenshot 98
 - textbox 97
 - Lamp menu 84, 86, 120
 - history 86
 - Mode 84
 - reset runtime 120
 - Runtime warning 86
 - runtimes 84
 - Signal menu 82–83
 - background 83
 - switching mode 82
 - Tools 75
 - PiP 75
 - Tools menu 76–80
 - PiP add window 77
 - PiP Adjust 80
 - PiP delete layout 80
 - PiP layout 78
 - PiP remove window 78
 - PiP rename layout 79
 - PiP Save 78
 - PiP select 76
 - Using the dialog boxes 41
 - menu bar 98
 - Menu structure 41
 - Using the dialog boxes 41

N

- Native resolution 55
- No signal 83
 - background 83

O

- Orientation 31
 - projector orientation 31

P

- Packaging 5
- Password 110
 - change password 110
- PiP 76–80
 - add window 77
 - adjust 80
 - layout 78
 - Layout 78–80
 - delete 80
 - rename 79
 - save 78
 - remove window 78
 - select 76
- PiP layout 37
- Preferences 33
- Projector 28
 - Switch on 28

Q

- Quick access keys 34

R

- RCU 25–26
 - Terminology 26
 - Overview 26
- Removing 11
 - lens 11
- Runtime 86, 120
 - reset 120
 - warning 86

S

- Scenergix 105
 - Black level 105
- Screenshot 98
- security 107
- setup 34
 - automatic startup 34
- Setup 25
- Sliderbox position 99
- Soft Edge 101, 103
 - Border adjustment 103
 - Horz. overlap zone 103
- Introduction 101
- Softedge 103
 - horizontal 103
 - overlap zone 103
- Source 42, 82
 - Source selection 42
 - switching mode 82
- Source selection 43–44
 - composite video 43
 - S-Video 44
- Start up 37
- Startup screen 97
- status bar 98
- Switching 82
 - switching mode 82

T

- Table overview 111
- Textbox 97
- Timer 46
- Tools 75
 - advanced 75
 - tools 75
- troubleshoot 115
 - OSD 115
- Troubleshoot 115

U

Unpacking 5

V

Video 19–20, 73–74
AGC 73

Composite Video 19
manual gain control 74
S-Video 20

W

White peaking 60

LIST OF IMAGES

3-5	location of the lens handle	11
3-10	source input section with optional SDI layer.....	18
3-11	Cable basket : the white arrow shows the cables leaving the projector.....	18
4-1	Local keypad layout	25
5-5	Video/Data PiP layout	38
6-23	Common non- anamorphic aspect ratios in DVD sources	53
6-24	Anamorphic aspect ratios in DVD sources	53
6-25	Possible aspect ratio settings and their effect on different sources in the iQ.....	54
6-31	Top adjustment of the keystone.....	57
6-32	Bottom adjustment of the keystone	57
6-35	film to video conversion: 2/2 and 2/3 pull down method	59
6-40	The CIE chromaticity diagram	61
6-41	The projector color gamut is defined by the triangle formed by the x, y coordinates of Red Green and Blue	61
6-42	The color gamut of each projector will differ	62
6-43	Common Color Gamut	62
6-44	The Common Color Gamut	63
6-49	Red coordinates for both projectors	69
6-50	Coordinate is not present within the gamut of the adjusted projector	69
6-51	Select a coordinate that is present in the common gamut	70
6-61	PiP: 2by2 layout	75
6-72	PiP adjust in case of 2by2 layout	81
6-73	Zebra on a single color.....	82
6-74	Full color image.....	82
6-75	Result image after color keying	82
6-80	Single mode operation: switching principle	85
6-114	Why Soft Edge?	102
6-115	Light modulation in Soft Edge.....	102
6-116	Scenergix set up.....	103
6-118	Width selections	104
6-119	Width set up for projector 1	105
6-120	Width set up for projector 2	105
6-122	Black level adjustment	106
9-1	location of the filters	118
9-2	Location of the x-cube filter and its handle	118
9-3	Lamp filter removal	118
9-4	lamp & X-Cube filters removed	118
9-5	Input filter removal.....	119
9-6	Input filter removed.....	119
9-12	Unlock the lamp	122
9-14	Lamp removed	123